

SOIL EROSION AND SEDIMENT CONTROL GUIDELINES
FOR
FOREST HARVEST OPERATIONS IN MARYLAND

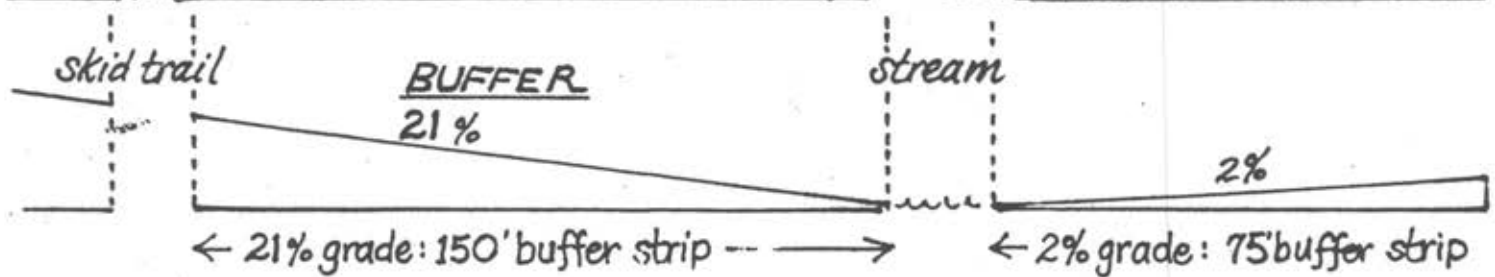

Prepared by
Maryland Department of the Environment

TABLE OF CONTENTS

	<u>PAGE</u>
INTRODUCTION	
SEDIMENT CONTROL PLANS	
Obtaining An Approved Plan.....	1
Requirements of the Standard Sediment Control Plan.....	2
Modification of Standard Sediment Control Plans.....	4
Buffer Management Plans.....	6
PERMITS	
County Permit Requirements.....	9
Water Resources Administration Permits.....	9
CRITERIA	
Straw Bale Dike.....	10
Silt Fence.....	11
Stabilized Harvest Entrance.....	12
Truck Haul Road.....	14
Broad Based Drainage Dip.....	16
Pipe Culvert.....	18
Wooden Box and Pole Culverts.....	21
Water Bar Thank-You-Ma'am, and Water Break.....	22
Major Skid Trail.....	23
Log or Sawn Timber Stringer Bridge.....	25
Mulching and Final Stabilization.....	30
APPENDICES	
1. Soil Conservation Dist. Offices for Each Maryland County.	34
2. State of Maryland Forestry Offices.....	37
3. Sample Plan Modification.....	41
4. Calculation of Cross-Sectional Area of Streams.....	42

INTRODUCTION

In an effort to protect our natural resources, the State of Maryland has developed a program designed to minimize the harmful effects of sedimentation resulting from earth disturbing activities. This program requires that individuals conducting clearing, grading, and forest harvest operations must obtain and implement a plan designed to prevent sediment pollution. This manual has been prepared to assist foresters, consultants and loggers in developing a suitable plan, and in conducting timber harvesting in a manner which will limit the amount of sediment pollution during harvest operations.

Forests are recognized as one of the most effective habitats for removing sediment and nutrients from runoff and groundwater before they reach a watercourse. It is essential, therefore, that the pollution buffering capacity of the forest not be destroyed during a timber harvest. Proper planning and harvest techniques will ensure that the timber can be removed in an economical manner while preventing major damage to our waterways.

SEDIMENT CONTROL PLANS

Obtaining An Approved Plan. Maryland State law and regulations require that a sediment control plan be developed and approved before undertaking any earth disturbing activity in excess of 5,000 sq. ft. To assist loggers in meeting this requirement, the Stormwater Management Administration (SMA) and Maryland Forest Park and Wildlife Service (MFPWS) have developed a Standard Plan for Forest Harvest Operations. This plan lists the general sediment control requirements for each harvest and may be obtained at any Soil Conservation District Office.

When a harvest is planned on private property, it is necessary to go to the local Soil Conservation District to obtain the plan and receive approval. Harvests on State and Federal land require plan approval by the SMA. A provision of the plan requires that the landowner also agree to follow the sediment control requirements. If the landowner is not able to go with you to the Soil Conservation District office, you may wish to have them sign a copy in advance. You can then take it to the district and speed up the approval process. A list of Soil Conservation District office locations and phone number's is presented in Appendix 1 for each county. Assistance in preparing plans may also be obtained from the Maryland Forest Park and Wildlife Offices listed in Appendix 2.

Requirements of the Standard Sediment Control Plan

The potential for loss of sediment from a timber harvest site primarily is at three general locations; access points to the site, roads, trails and landings, and adjacent to watercourses. The Standard Plan, therefore, emphasizes sediment control in these areas. Instructions for installing the required sediment control practices are listed in the specification sections of this document. The primary requirements for these areas are as follows.

Site access:

Access points to the site which lead from a paved road must be protected with stone, wood chips, corduroy logs, wooden mats or other materials which will prevent soil or mud from being tracked onto the road. It is also necessary to prevent the existing drainage pattern from being blocked or damaged by the access construction. A culvert placed underneath the road entrance is the most effective way to maintain proper drainage.

Trails and Landings:

Advance planning of the location of roads, trails and landings is one of most effective ways to minimize the potential for soil erosion. Locating roads and trails along natural contours and minimum slopes reduces the need for substantial cutting and filling operations.

When planning the road system avoid stream crossings whenever possible as they create one of the greatest sediment pollution hazards. Temporary stream crossing permits will be required if the drainage area above the crossing point exceeds 400 acres (contact Water Resources Administration for trout waters). Stream crossings must be constructed properly to prevent streambank damage and subsequent erosion.

Waterway Protection:

Protecting watercourses from runoff and equipment damage is the most critical aspect of sediment control during harvest operations. Improper stream crossings, soil disturbance adjacent to streams, and logging debris left in streams may result in substantial sediment pollution and flooding.

To protect streams and other watercourses, the Standard Plan requires that uncut buffer strips be left on either side of the watercourse. The undisturbed buffer will intercept sediment laden water and filter out the sediment. Equipment is to be kept out of buffer areas to prevent soil compaction. If soil within a buffer becomes compacted rainwater will not soak into the soil as effectively, and may enter the stream as sediment laden runoff. Runoff into streams also increases the volume of flow, thereby accelerating streambank erosion and flooding potential.

Additional Requirements:

In addition to the practices listed for the above areas, it is necessary to stabilize certain portions of the harvest site with seed and/or mulch to prevent future erosion. This requirement generally applies to roads, trails and landings which would not regenerate natural vegetation because of steep slopes.

Modification of Standard Sediment Control Plans.

Situations may arise when it is not possible, even with careful planning, to comply with all the requirements of the Standard Plan. The slope of the land may be such that road cuts or fills and roads, trails or landings cannot meet the minimum requirements of the Standard Plan. If all the conditions of the Standard Plan can not be met it is necessary to have a plan amendment prepared by a Registered Professional Forester prior to Soil Conservation District approval of the plan. The modification can be prepared either by State or private consultant foresters.

It is important that two types of information be included with plan modifications. The first is the location of the modification and the second is the specific sediment control to be used. The location of the modification should be described on a sketch of the job site. Once the area where a plan modification is to occur has been identified, it is necessary to describe the extra precautions that will be taken to ensure adequate sediment control. For example, if road grades are to exceed fifteen percent, and turnouts are to be used to drain water from the road, the location of the turnouts should be noted on the plan sketch. To prevent water from the turnout from creating side bank erosion it may be necessary to install stone at the point where the water is discharged. The location of the stone should also be identified on the plan modification sketch.

Another example would be where a landing must be located on a slope exceeding ten percent. It may be necessary to install a silt fence or straw bale dike on the downslope side of the landing to act as a sediment barrier.

In this case, the location of sediment controls and the type of final stabilization to be used at the landing should be noted on the plan. In summary, the important thing to remember is that it is necessary to identify the location and describe the specific sediment controls to be used whenever a plan modification is prepared. An example of a plan modification is presented in Appendix 3.

Buffer Management Plans

The Standard Plan for Forest Harvest Operations requires that uncut buffer zones be maintained on all sides of perennial or intermittent streams, rivers, lakes, ponds, bogs or marshes. The width of the buffer is dependent upon the slope of the land adjacent to the watercourse. Because of the high potential for soil compaction, erosion and stream damage, roads, trails and harvesting equipment are not allowed in the buffer except to provide access to stream crossings. The Standard Plan does, however, allow limited harvesting within the buffer, provided that a buffer management plan is prepared by a registered professional forester. Buffer management plans need to be very specific in describing which trees are to be cut, what precautions for sediment control will be taken, and where the sediment controls will be located. The location of any harvesting within a buffer must be identified on a sketch of the buffer. The sediment controls to be used for waterway protection and topography within the buffer must also be located on this sketch.

Buffer management plans should be prepared in accordance with the following guidelines.

- A. A sketch shall be prepared which identifies all buffer areas to which the management plan applies. The location of any roads, trails or stream crossings shall be noted on the sketch. It should be noted, however, that buffer management plans may not provide for any roads, trails, or equipment within the last 50 feet (adjacent to the watercourse) of any buffer, except to access stream crossings.

Harvesting within a buffer will require the installation of specific sediment control measures and seeding and/or mulching of soil exposed during the harvest. The sketch should also note the location of any sediment controls, such as silt fence or straw bale dikes which are to be used.

- B. The objective of the buffer management plan is to ensure that an effective (60 square feet/acre minimal basal area of evenly distributed trees, which are 6 inches or greater in diameter) wooded buffer remains after harvest and that there is no damage to the humus and litter layers within the buffer.
- C. Stream crossings are to be avoided and are to be allowed only when access to the other side is not possible within the bounds of the owner's land. Streams draining more than 400 acres (contact WRA for trout waters) may not be crossed except in accordance with a stream crossing permit. Streams draining less than 400 acres (contact WRA for trout waters) will not require a permit, but crossings should be constructed in accordance with the guidelines presented in the specifications for stream crossings, listed in later chapters. A sketch identifying any crossing locations shall be included in the plan.
- D. Except for stream crossings, no roads or trails shall be permitted within buffer zones. Use of wheeled or tracked equipment shall be limited so that the humus layer will not be removed or compacted to limit its water holding capacity. Damage to the humus layer will be repaired immediately.
- E. The approximate basal area to be removed and retained shall be specified in the plan, as well as the method of harvest and provisions to ensure that sufficient regeneration is established. Any restriction on harvesting during adverse weather conditions should also be included.

- F. Trees scheduled for removal are to be individually marked at eye level and at the base to facilitate enforcement and avoid confusion during the harvest.
 - G. No material originating outside the buffer zone may be deposited within the buffer.
 - H. Trees should be felled away from the streambanks thereby keeping the tops and slash well away from the water and in such position that they cannot be moved into the stream by flood waters.
 - I. Any exposed soil within the buffer shall be seeded and mulched according to the requirement of final stabilization. This notation must appear in the buffer management plan.
 - J. Any proposed activity within the buffer strip must not lead to contamination of a watercourse by sediment or any other pollutant.
- Each site must be evaluated on its own individual characteristics and limitations. The above list represents a nucleus upon which to build in order to achieve water quality goals.

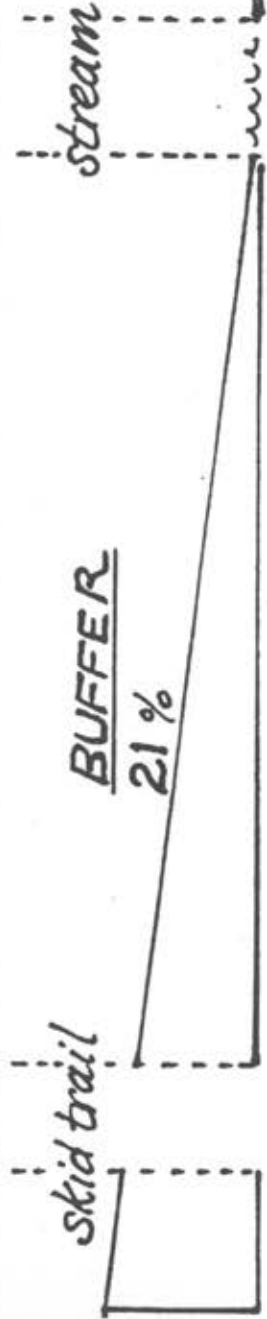
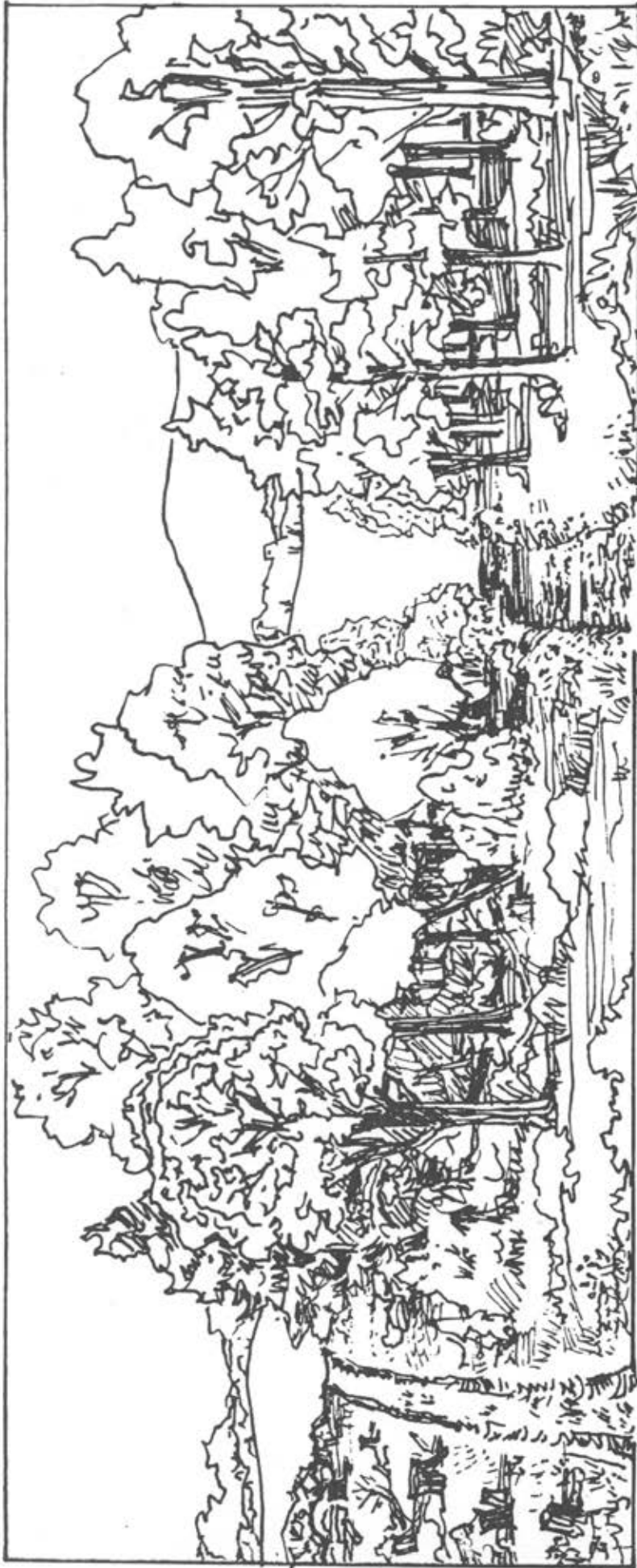

← 21% grade: 150' buffer strip →

← 2% grade: 75' buffer strip

PERMITS

County Permit Requirements

Many counties in Maryland do not require a permit for forest harvest operations. In those counties, all that is necessary is to obtain an approved plan from the local Soil Conservation District, and any necessary stream crossing permits from the State Water Resources Administration. Some counties do, however, require that a county permit be obtained prior to the harvest. Procedures among the counties for obtaining this type of permit may vary.

Water Resources Administration Permits

The best practice in planning a timber harvest is to avoid having to cross any streams. If a stream crossing is unavoidable, the State of Maryland, Water Resources Administration, requires that a stream crossing permit be obtained if the drainage area above the crossing exceeds 400 acres (contact WRA for trout waters). Information concerning these permits may be obtained from any Soil Conservation District office or by calling the Water Resources Administration, Waterway Permits Division (301) 974-2265.

CRITERIA
FOR
STRAW BALE DIKE

Definition

A temporary barrier of straw or similar material used to intercept sediment laden runoff from small drainage areas of disturbed soil.

Purpose

The purpose of a straw bale dike is to reduce runoff velocity and effect deposition of the transported sediment load. Straw bale dikes are to be used for no more than three (3) months.

Design Criteria

All bales shall be placed on the contour with cut edge of bale adhering to the ground. See Standard Drawing SBD-1 for details.

STRAW BALE DIKE

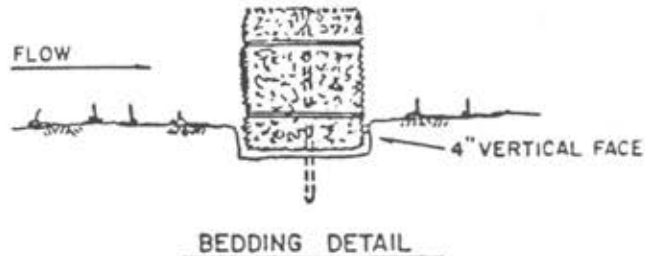

STANDARD SYMBOL

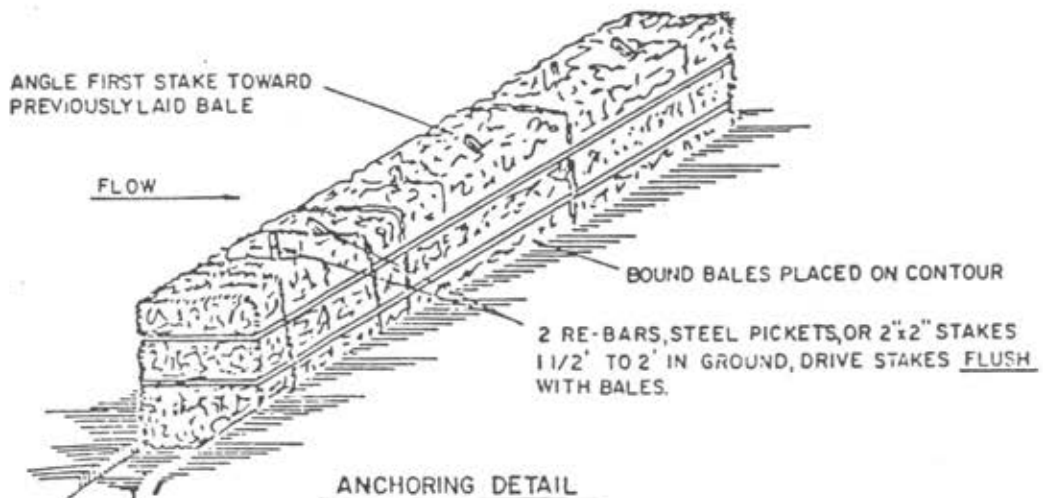

ANCHORING DETAIL CONSTRUCTION SPECIFICATIONS

1. BALES SHALL BE PLACED AT THE TOE OF A SLOPE OR ON THE CONTOUR AND IN A ROW WITH ENDS TIGHTLY ABUTTING THE ADJACENT BALES.
2. EACH BALE SHALL BE EMBEDDED IN THE SOIL A MINIMUM OF (4) INCHES, AND PLACED SO THE BINDINGS ARE HORIZONTAL.
3. BALES SHALL BE SECURELY ANCHORED IN PLACE BY EITHER TWO STAKES OR RE-BARS DRIVEN THROUGH THE BALE. THE FIRST STAKE IN EACH BALE SHALL BE DRIVEN TOWARD THE PREVIOUSLY LAID BALE AT AN ANGLE TO FORCE THE BALES TOGETHER. STAKES SHALL BE DRIVEN FLUSH WITH THE BALE.
4. INSPECTION SHALL BE FREQUENT AND REPAIR REPLACEMENT SHALL BE MADE PROMPTLY AS NEEDED.
5. BALES SHALL BE REMOVED WHEN THEY HAVE SERVED THEIR USEFULNESS SO AS NOT TO BLOCK OR IMPEDE STORM FLOW OR DRAINAGE.

	STRAW BALE DIKE	STANDARD DRAWING
		SBD-1

CRITERIA
FOR
SILT FENCE

Definition

A temporary barrier of geotextile fabric (filter cloth) used to intercept sediment laden runoff from small drainage areas of disturbed soil.

Purpose

The purpose of a silt fence is to reduce runoff velocity and effect deposition of transported sediment load. Limits imposed by ultraviolet stability of the fabric will dictate the maximum period the silt fence may be used.

Design Criteria

Design computations are not required. All silt fences shall be placed as close to the contour as possible, and the area below the fence must be undisturbed or stabilized.

The bottom of the silt fence must be placed into a trench dug 8 inches into the ground on the uphill side. The trench should then be backfilled and compacted.

Silt Fence

Standard Symbol -S-S-

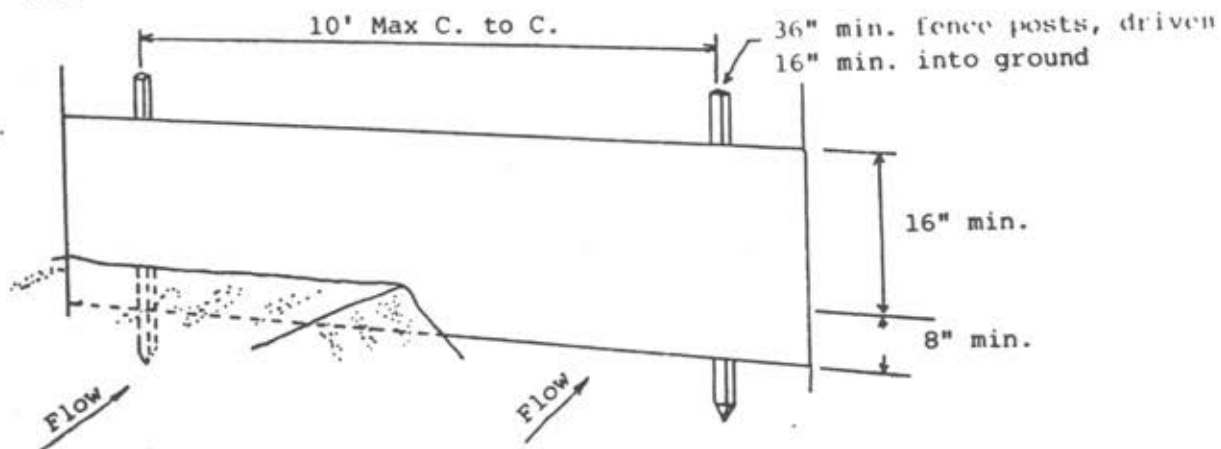

Perspective View

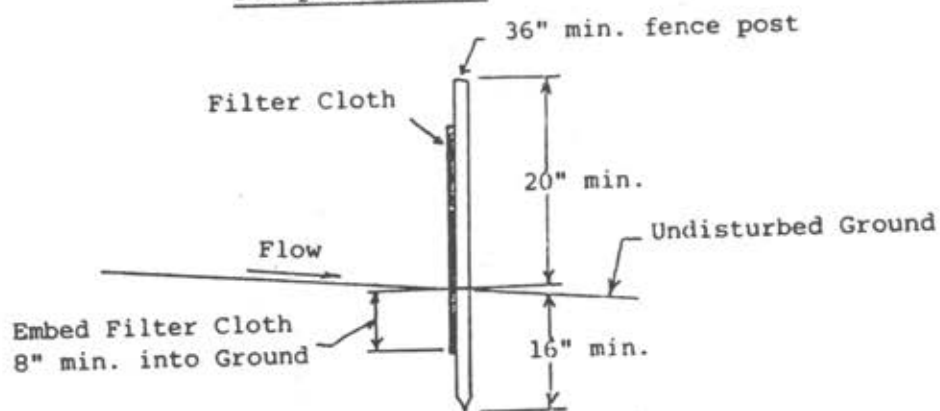

Section

Silt Fence Construction Specifications

1. Silt fences must be embedded, or keyed in, at least 8 inches into the ground. Laying the lower edge of the filter fabric on the ground and covering it with soil is not an acceptable method of keying in. The key-in trench can be excavated by hand or by ditching equipment. After the silt fence is constructed, the trench must be backfilled and compacted.
2. Fence posts must be:
 - a. at least 36 inches long, and
 - b. have a cross sectional area of at least 3 square inches if wooden, or
 - c. weigh at least 1 pound per linear foot if steel T or U type, and
 - d. on 10 foot maximum centers, and
 - e. driven at least 16 inches into the ground.
3. The filter fabric must be fastened securely to the fence posts.
4. When two sections of filter fabric are joined together, the joint must occur at a fence post. The ends of the filter fabric should be overlapped by at least 6 inches, folded, and fastened to the fence post so that no gaps in the fence occur. Manufacturer's recommendations for joining fabric sections may be followed as long as the resulting joint does not create gaps in the silt fence.
5. Silt fences must be inspected periodically and after each rain event and maintenance performed as necessary.

CRITERIA
FOR
STABILIZED HARVEST ENTRANCE

Definition

A stabilized pad or mat and drainage protection at any point where equipment will be entering or leaving a harvest site to a public right-of-way.

Purpose

To eliminate or reduce tracking of sediment onto roads and public rights-of-way and to protect existing drainage patterns.

Design Criteria

Stabilized entrances:

The following practices provide acceptable stabilized entrances.

Aggregate Pad - 2" stone, or reclaimed or recycled concrete or its equivalent placed to a thickness of at least (6) inches.

- Mats -
- a) Corduroy mats made from on-site material of six (6) inch minimum diameter.
 - b) Steel mats designed to support heavy equipment on the existing base.
 - c) Wooden pads or mats designed to support the equipment on the existing base. These may be constructed either by cabling or nailing together rough sawn timber which is 2" to 8" thick.

Minimum Size of Stabilized Entrances:

Width - Ten (10) foot minimum, but not less than the full width of access points.

Length - Fifty foot minimum and as long as required to prevent the majority of sediment from leaving the site.

Drainage Protection:

The drainage pattern existing along any road must be protected from any disturbance that will block the drainage.

To protect the drainage at entrances, a pipe or bridge shall be installed. The drainage pattern shall be restored to its original condition upon completion of the harvest.

Exceptions:

State and Local jurisdictions may have requirements that exceed these minimum requirements for entrance to a public road.

Alternate materials and methods such as wood chip entrances, may be used if they accomplish the objectives and are approved in advance by the local Soil Conservation District. Wood chips should not be used for crossing agricultural fields.

Maintenance:

The entrance shall be maintained in a condition which will prevent tracking of sediment onto a public road. This may require periodic additional top dressing of aggregate or other maintenance. All sediment, spilled, dropped or tracked onto a public right-of-way must be removed immediately and returned to the site. No sediment may drain onto a paved public right-of-way.

When necessary, truck wheels must be cleaned to remove sediment prior to exiting onto a public right-of-way.

CRITERIA
FOR
TRUCK HAUL ROADS

Definition

A road system, temporary or permanent, to remove products from the harvest site by truck. A single lane road system installed by grading with a bulldozer or other mechanical equipment which may incur a series of minor cuts and fills.

Purpose

To permit the efficient removal of primary forest products (i.e. sawlogs, piling, pulpwood) by truck from the harvest site.

Design Criteria

1. Final centerline grade of road will be 10% or less. Steeper gradients, not to exceed 15%, will be allowed for distances up to 200 feet. By breaking or changing grade frequently, less erosion problems will be encountered than on long, straight continuous gradients.
2. Free flowing watercourses will be bridged or culverted as close to a right angle to the stream as possible. Culverts shall be sized as not to impede stream flow (See pipe culvert).
3. Road gradients approaching water crossings should be adverse or broken and surface water dispersed so it will not reach the watercourse.
4. Roads will be located (with the exception of stream crossings) outside of any required buffer strip.
5. Roads may be outsloped for cross drainage. On side hills where a curb, fender or berm is necessary to protect the fill slope, the road will be insloped with cross drainage installed from the inside toe of slope to the outside or downhill side. Roads should be insloped for safety reason on sharp turns and slippery soils.

6. Where roads are insloped as described above, cross drain interception of surface water will be required 25 feet up-grade of any stretches of road where gradients exceed 10%.
7. All cuts and fills greater than three feet shall be graded to a slope not exceeding 3:1, and shall be stabilized with seed and mulch.
8. Specifications for construction of haul road drainage and diversion structures are described in subsequent chapters.

Truck Haul Road Maintenance

1. During construction, adequate drainage of the road surface is required on a day to day basis.
2. During the harvest operation roads and their attendant drainage systems will be maintained to perform to standard. Road surface slopes will be regraded for proper drainage, and drainage paths kept clear of logging debris. Culverts and cross drains will be kept in an open condition.
3. Any drainage system malfunction will be corrected immediately.
4. Operations should not be continued during extreme weather conditions that will cause adverse erosion and sediment problems.

Post Harvest Operations

1. All temporary drainage structures will be removed and natural surface drainage restored with post harvest practices such as water breaks.
2. Other stabilization measures may be required depending on the slope of the road grade. (see specifications for stabilization)

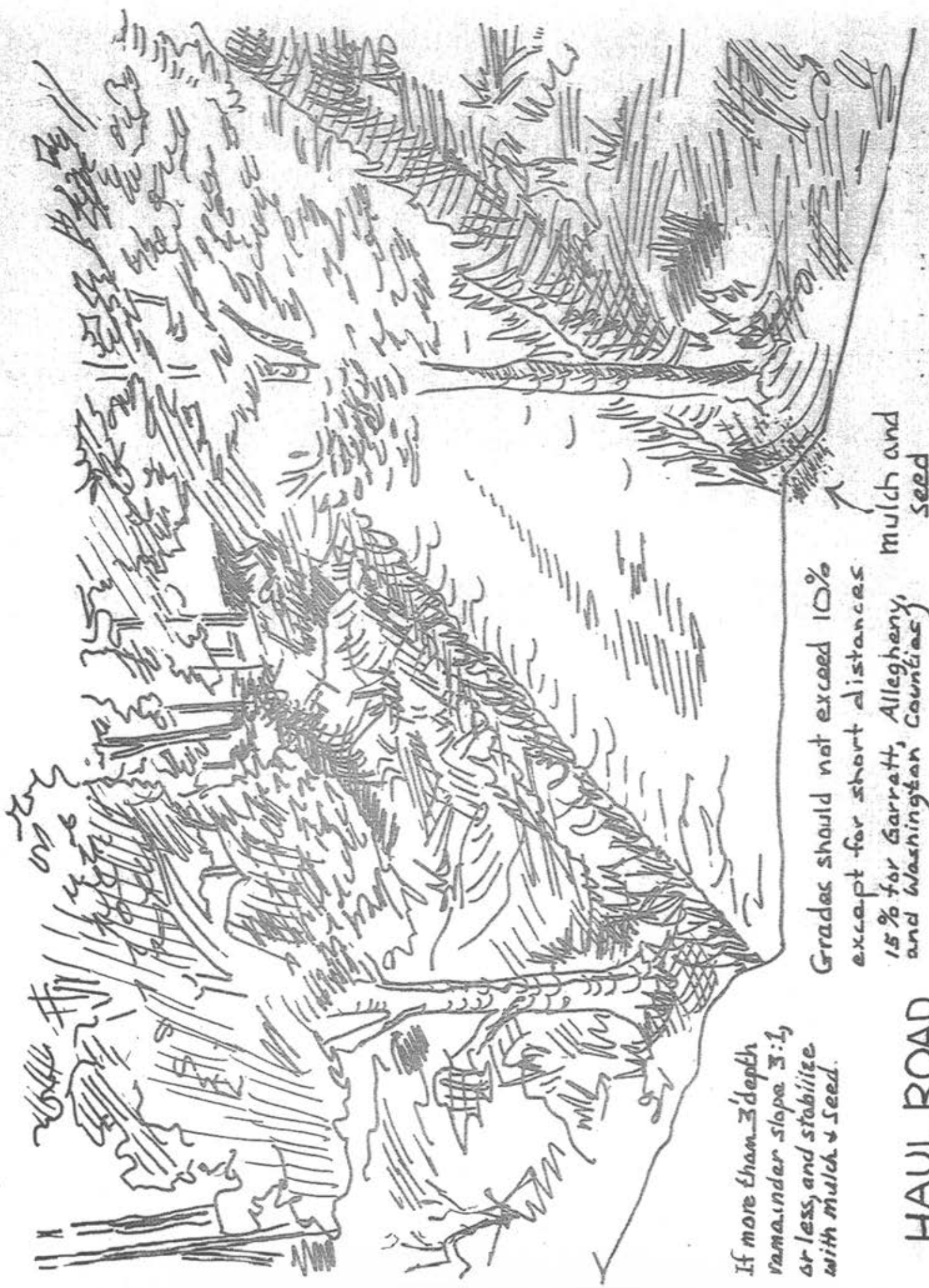

If more than 3' depth
remainder slope 3:1,
or less, and stabilize
with mulch & seed.

Grades should not exceed 10%
except for short distances
15% for Garrett, Allegheny,
and Washington Counties, mulch and
seed

HAUL ROAD

CRITERIA
FOR
BROAD BASED DRAINAGE DIP

Definition

A dip and reverse slope in a road surface with an outslope in the dip for natural cross drainage, used to divert water away from the road surface.

Purpose

To provide cross drainage on insloped truck roads and major skid trails to prevent build up of excessive surface runoff and subsequent erosion. Broad based dips can be used on truck haul and heavily used skid trails having a gradient of 10 percent or less.

1. Installation takes place following basic roadbed construction.
2. Begin construction by locating the discharge point; usually a low point in the road grade. Place a stake at the edge of the road on the inslope side.
3. Walk downhill approximately 20 feet and place another stake at the edge of the road.
4. Begin excavating at the downhill stake and cut to a point approximately 15 feet beyond the uphill stake. To provide cross drainage, the cut should be somewhat deeper on the outslope of the road. The maximum depth of cut should be at the uphill stake, reaching 41 inches on the inslope and 8 inches on the outslope. The outslope grade should be at right angles to the road centerline.
5. Compact the area and cover the dip with 6-8 inches of 2-4 inch stone for roadbed protection. The stone may not be necessary if the roadbed is composed of shale or bedrock.
6. Place stone at the discharge point to discharge water being channeled from the road surface.

7. All side cast material should be stabilized with seed and/or mulch.
8. Spacing of broad based dips will be determined by the following formula:

$$\text{Spacing} = \frac{400 \text{ ft}}{\text{slope percentage}} + 100 \text{ ft.}$$

(ft.)

For example= Dips would be spaced at 140 ft. intervals on a road with a 10 percent slope.



← gravel →

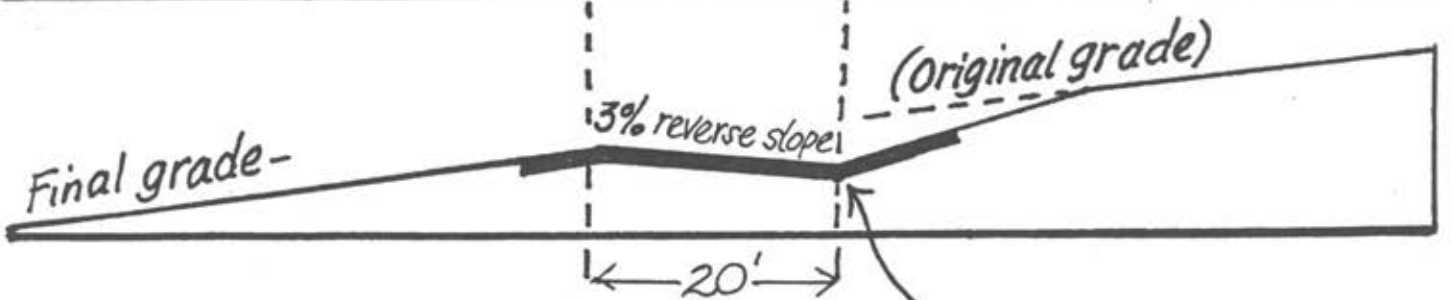
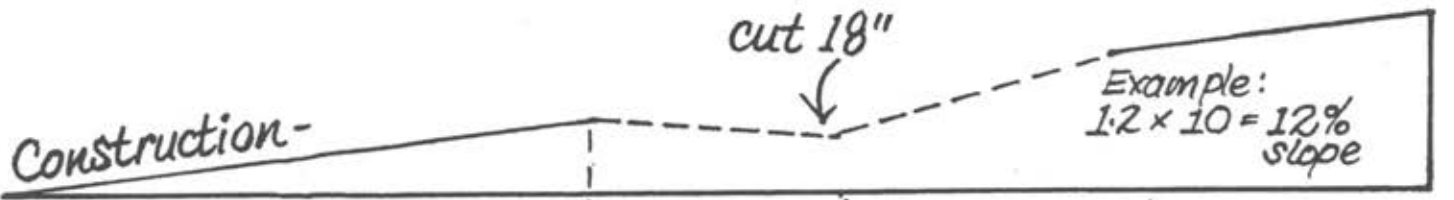
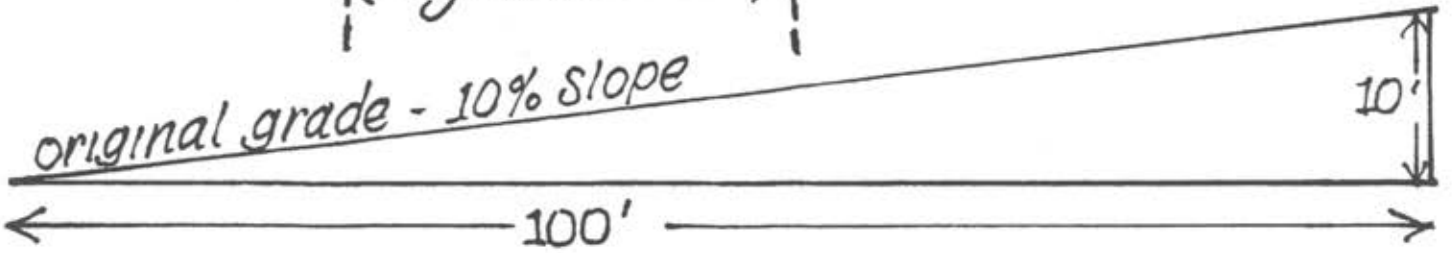

spacing = $\frac{400}{\text{slope}\%} + 100\text{ft.}$

The BROAD-BASED DIP

CRITERIA
FOR
PIPE CULVERT

Definition

Corrugated metal pipe or other suitable pipe material placed under a haul road or a major skid trail to transmit side ditch runoff, spring seeps and small intermittent or perennial streams.

Purpose

To collect and transmit water flows from side ditches, or seeps, and intermittent or live streams under haul roads and skid trails safely without eroding the drainage system or road surface.

Design Criteria

Note: These criteria only apply to crossings which do not require a stream crossing permit. When stream crossing permits are required, the culvert size should equal sixty percent of the cross sectional area of the stream channel. See Appendix 4 for instructions on calculating cross sectional area.

Streams:

1. Pipe diameter should be sized according to the following drainage area criteria.

<u>Drainage Area Above Pipe (Acres)</u>	<u>Required Pipe Diameter (inches)</u>
less than 10	12
10-16	15
17-25	18
26-40	21
41-55	24
56-84	30
85-130	36
131-190	42
191-260	48
261-335	54
336-400	60

2. Pipe length should be long enough so both ends extend beyond the toe of side slopes.
3. Fill material should be one foot or more over the pipe, and more than one-half the pipe diameter between multiple pipe installations.
4. Fill at pipe ends must be rip-rapped to stabilize all unstable side slopes.
5. Pipe gradient should be the same as the stream gradient with pipe alignment the same as the stream course or thread.
6. The pipe should be embedded in the stream bottom to allow fish migration.

Cross Drainage:

1. The pipe length should be long enough so that the outside end extends beyond any cast fill.
2. The pipe gradient should match that of the contributing ditch and have at least a two percent slope.

3. Installation should be skewed 30-45 degrees downgrade.
4. An energy dissipator will be provided for outflows of culverts to minimize erosion downslope or downstream of the outfall.

Low Water Bridge:

1. A low water bridge is a combination of a culvert stream crossing and ford for permanent installation.
2. The bridge is made of a culvert sized to accomodate normal flow. The culvert is back filled and covered with concrete to provide the travel surface, usually formed with a low dip to the center.
During high water, the flow is then over the stabilized structure.

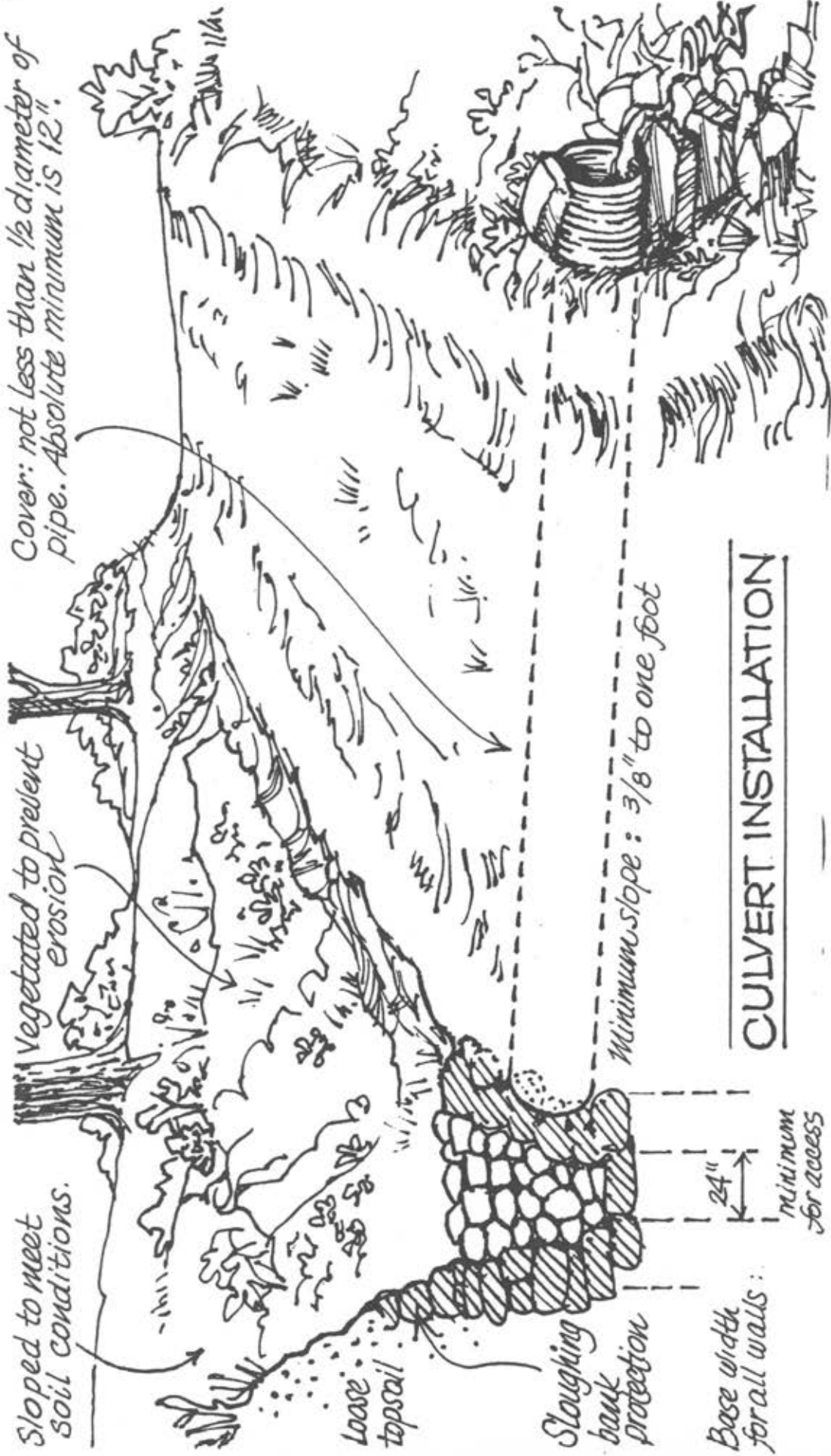

CULVERT INSTALLATION

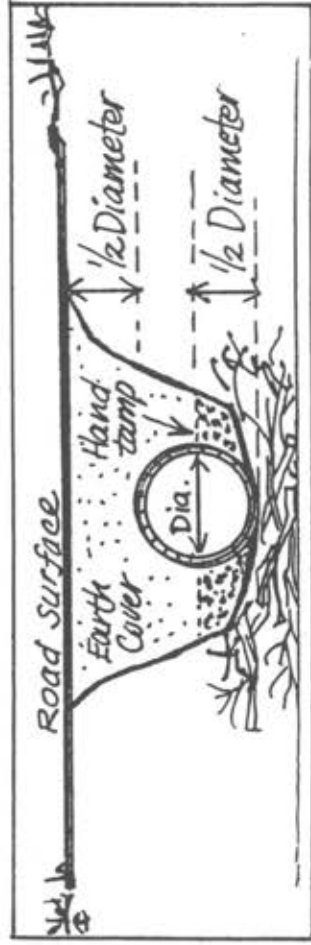
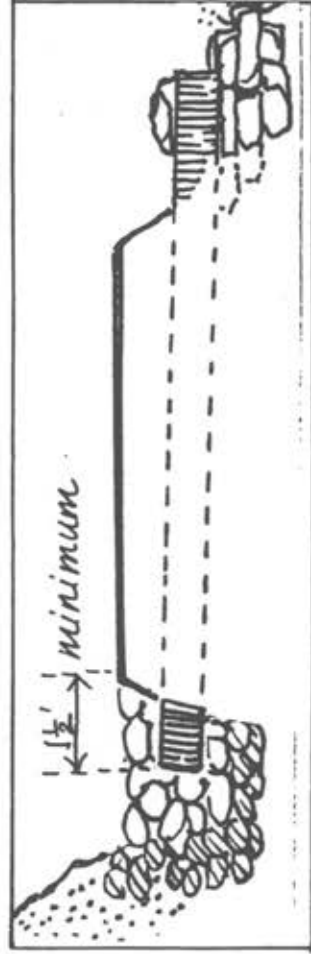

CRITERIA
FOR
WOODEN BOX AND POLE CULVERTS

Definition

A wooden culvert placed across truck haul roads to convey road surface runoff and side ditch flows across road surface to downslope side.

Purpose

To collect and direct road surface storm runoff and upslope side ditch flows across a road without eroding the drainage system or road surface. This is a temporary drainage structure for on-going operations. Properly built and maintained, it can be used for cross drainage on truck haul roads of smaller operations as a substitute for a pipe culvert. This practice should not be used for handling intermittent or live streams or skid trail cross drainage.

Design Criteria

1. Box and pole culverts are to be installed flush with the road surface and installed at a 30 degree down-grade angle and a 3 percent fall.
2. The outfall will extend beyond the road surface with adequate rip-rap or other material to dissipate water velocity and assure no erosion of cast fill.
3. Planking may be nailed to the top of the culverts to facilitate truck crossing.
4. Spacing will be determined by the following formula:
$$\text{Spacing (in feet)} = \frac{400 \text{ ft.}}{\text{Slope percentage}} + 100 \text{ ft.}$$
5. Clean out maintenance must be accomplished frequently to remove sediment, gravel and logging debris.
6. These structures must be removed when the operation is completed and replaced with permanent surface drainage practices.

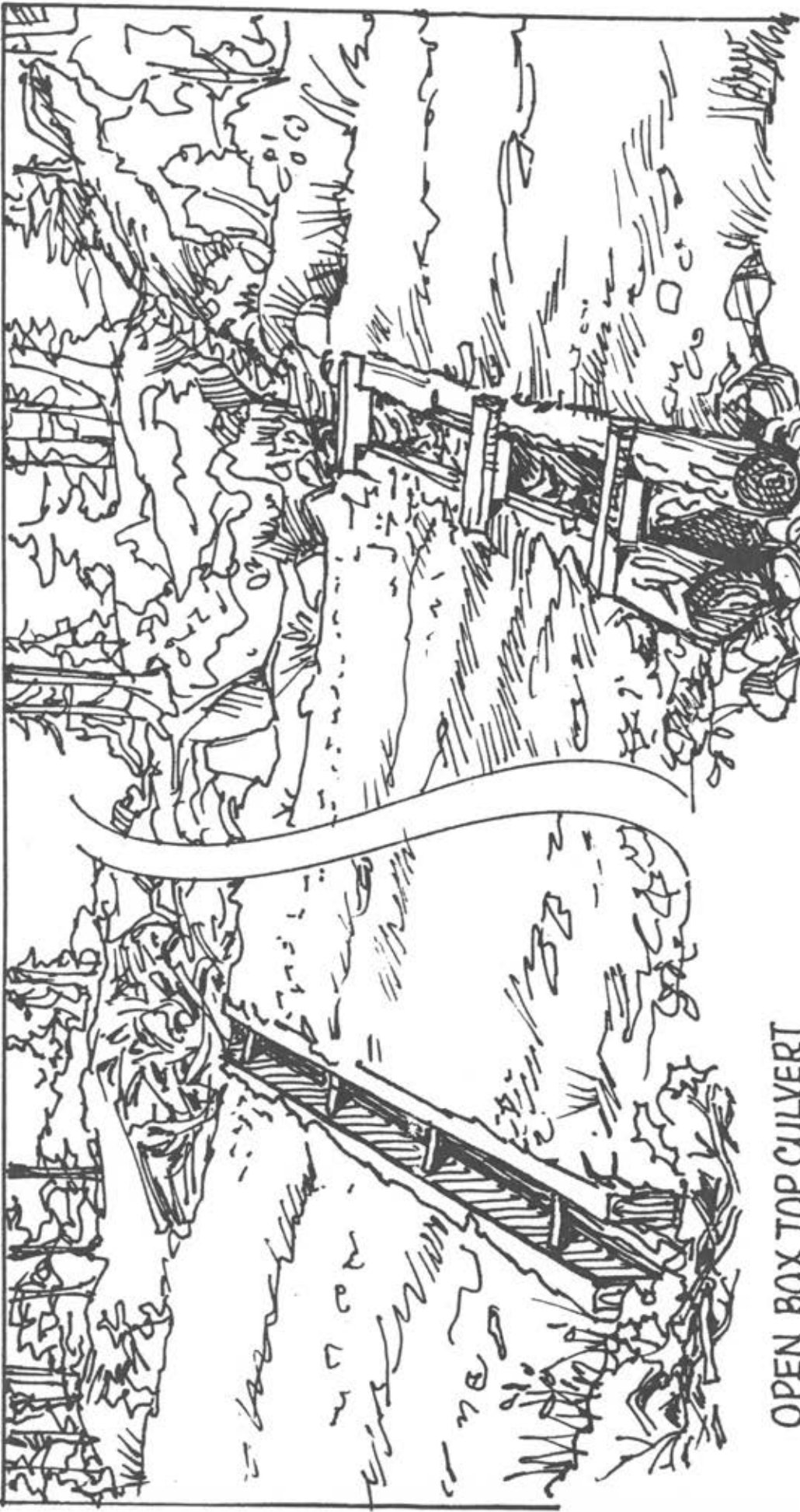

OPEN BOX TOP CULVERT

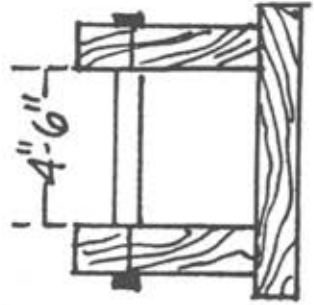

POLE CULVERT

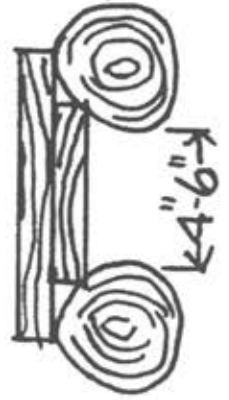

CRITERIA
FOR
WATER BAR, THANK-YOU-MA'AM AND WATER BREAK

Definition

A shallow trench or earth reinforcement constructed across a road or trail.

Purpose

To intercept and divert side ditch and surface runoff following completion of the harvest to minimize erosion and provide conditions suitable for natural or artificial revegetation. These are post harvest practices that can be utilized where surface water runoff may cause erosion on any sloping road or trail requiring stabilization.

Design Criteria

1. Proper spacing between water bars can be determined by using this formula.
$$1000 \div (\text{percent grade} + 2.5) = \text{Spacing (ft.)}$$
 Example for 7 percent slope.
$$\frac{1000}{(7+2.5)} = 105 \text{ ft. between water bars.}$$
2. Installation should be at an angle of 30 degrees downslope or more to turn surface water off the road or trail.
3. A shallow trench should be dug 3 to 4 inches below the surface of the road or trail and extend beyond both sides for a thank-you-ma'am.
4. A 5 to 8 inch pole should be placed in the trench and pegged and filled with soil on the downslope side for a water bar. A water break would use the dug material in place of the bar.
5. The uphill end of the bar should extend beyond the side ditch line of the road to fully intercept any ditch flows.
6. The outflow end of the bar should be fully open and extended far enough beyond the edge of the road or trail to safely disperse runoff water onto undisturbed forest floor. If any loose fill exists at the outflow, further stabilization is necessary.

WATER BREAKS

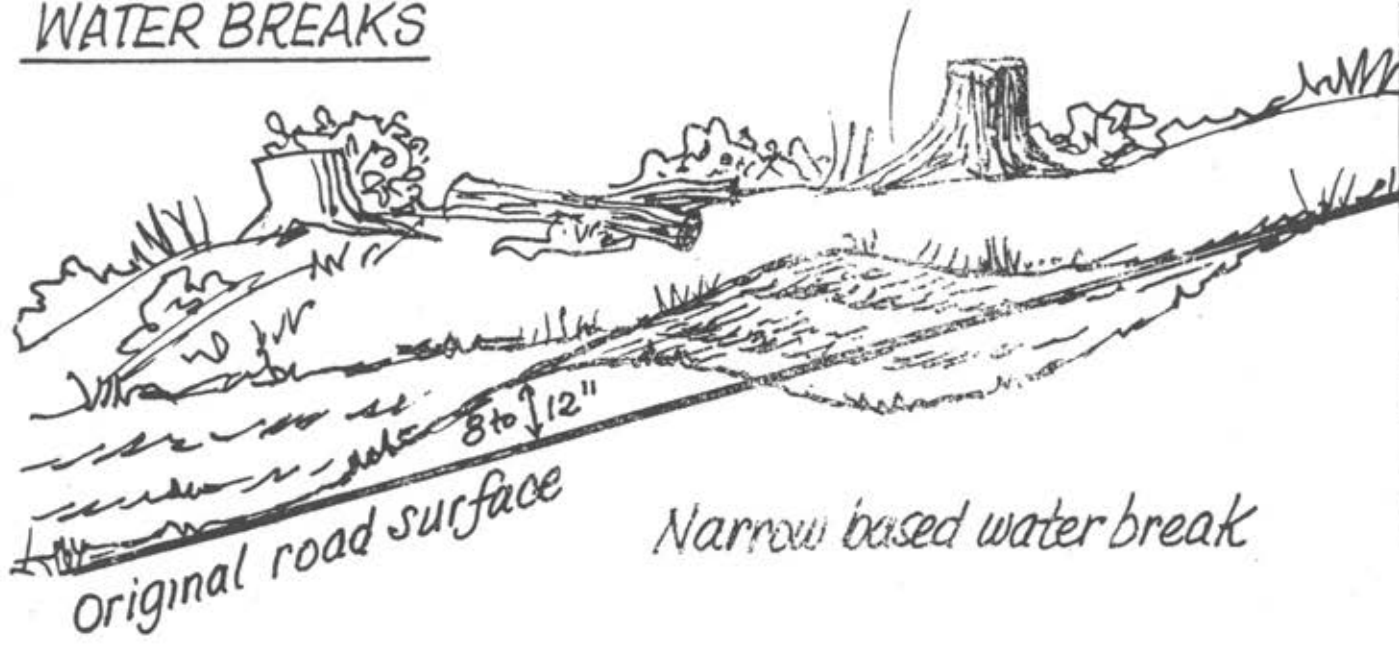

CRITERIA
FOR
MAJOR SKID TRAIL

Definition

An unsurfaced, single lane trail or narrow road usually steeper and narrower than a truck haul road used for skidding roundwood products.

Purpose

To skid logs, tree length timbers or other roundwood products from the stump to a common yarding or concentration area for loading trucks. This practice is used where roundwood removal requires centralized loading on trucks or trailers, and where topography and size of operation make skidding or pre-hauling the primary and most economical means of collecting trees, logs or other roundwood products.

Design Criteria

Major skid trails must have locations planned to minimize damage to the residual stand, and reduce erosion and sedimentation. The location should also be planned to minimize soil compaction.

1. Gradients shall not be steeper than 15% with the exception of short, steep segments not to exceed 20%.
2. Cross drainage (thank you ma'ams, broad based dips and turn outs) for dispersing surface water will be provided according to the gradient involved and the following spacing formula for water bars.

$$\text{Cross Drainage Spacing} = \frac{1,000}{\% \text{ grade} + 2.5}$$

(in feet)

3. Major skid trails will be located outside of buffer areas required for streams, rivers, lakes, bays, bogs and marshes.

4. Any skid trail necessitating the crossing of a live stream will require a bridge or culvert of acceptable design and a crossing permit if necessary.
5. A culvert of proper size will be required where intermittent streams or spring seeps cross the trail.
6. Approaches to water crossings will be as near right angles to the stream direction as possible.
7. Skid trails will be stabilized following completion of their use.

CRITERIA
FOR
TEMPORARY
LOG OR SAWN-TIMBER-STRINGER BRIDGE

Definition

A structure of wood or wood and steel materials temporarily installed across a natural or man-made channel or watercourse.

Purpose

To carry a single lane haul road or major skid trail over a watercourse.

Design Criteria

Note: These specifications apply to crossings which do not require a stream crossing permit. The Water Resources Administration may require additional measures when a permit is required. A temporary stream crossing permit is required to cross streams where the drainage area above the crossing exceeds 400 acres, or trout waters draining more than 100 acres.

Placement of bridges shall be at right angles to the stream or channel flow. Abutments will be placed on stable banks and be parallel to the direction of flow. Approachs shall be in alignment with the bridge center line with as little curvature as possible. Minimum acceptable bridge width is 10 feet.

1. Abutments: Abutments shall be firmly anchored in stable bank material and be parallel to the thread of the stream or channel.

Acceptable materials can be rock, logs, sawn timbers or a combination of any of the above.

Abutment aprons or approaches shall be as close to the gradient of bridge surface as possible. Abrupt rises or drops from bridge gradient to apron gradient shall be avoided. Elevation shall be above normal high water.

2. Stringer: Stringer material may be either logs, sawn timbers or steel.

Center line gradient of the span shall match that of road or trail.

The safe truck loading table at the end of this section, will aid you with determining the size and number of stringers required for any combination of load in tons and span.

Log stringers should have a flat upper bearing face to accept the plank deck as well as a flat bearing surface on abutments. Placement of log stringers on abutments should alternate small and large ends.

3. Deck: Placement shall be perpendicular to stringer direction and tight.
4. Curb: A curb or fender shall be installed along the outer sides of the deck and be fastened securely to the deck. Minimum size will be 6"x6" and will run the entire length of the span. Pole timbers can also be used, but must be straight and of sound quality.
5. Anchor: The structure must be anchored so it will not wash out during high water.
6. Substitute: Military portable temporary bridges or old trailer beds may suffice in certain situations.
7. Drainage: Drainage from approach roads shall be diverted to undisturbed forest floor and not permitted to drain directly into a watercourse.
8. Removal: A bridge will have to be removed within one year unless the terms of a permit are for permanent construction.

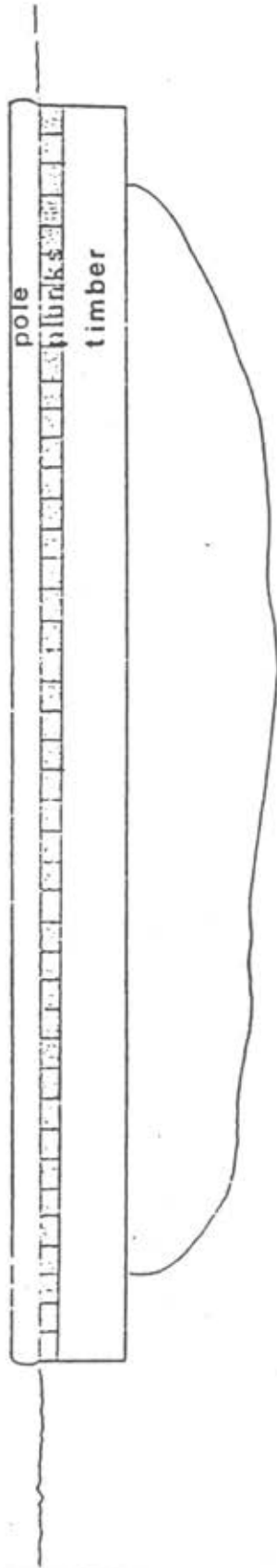
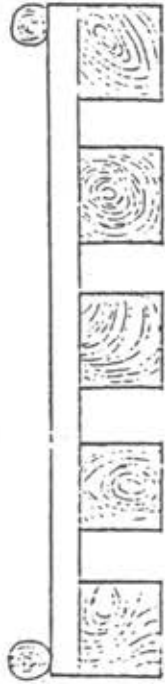
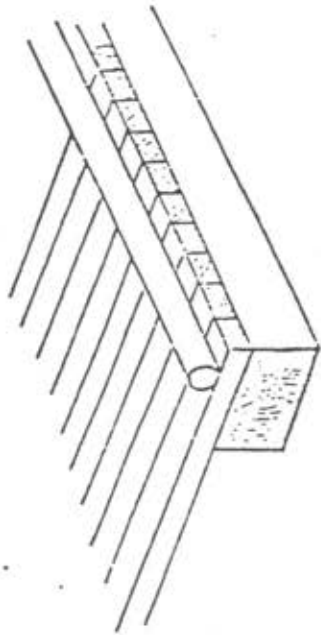

LOGGING ROAD BRIDGE

Safe Truck Loadings on Timber-Stringer Bridges

(In tons)

		6-INCH-DIAMETER STRINGER					
Clear Span:		Center-to-center spacing (inches)					
(feet) :	6 :	12 :	18 :	24 :	30 :	36 :	42
8	9.2	4.6	3.1	2.3	1.8	1.5	
10	7.5	3.7	2.5	1.8	1.5	1.2	
12	6.2	3.1	2.1	1.6	1.2	1.0	
		8-INCH-DIAMETER STRINGER					
8		11.0	7.4	5.5	4.4	3.7	
10		8.8	5.9	4.4	3.5	2.9	
12		7.4	4.9	3.7	2.9	2.5	
14		6.0	4.0	3.0	2.4	2.0	
16		5.2	3.5	2.6	2.1	1.7	
		10-INCH-DIAMETER STRINGER					
8		21.6	14.4	10.7	8.6	7.3	
10		17.3	11.5	8.6	6.9	5.7	
12		14.4	9.6	7.2	5.7	4.8	
14		11.7	7.8	5.9	4.7	3.9	
16		10.2	6.8	5.1	4.1	3.4	
18		9.1	6.1	4.5	3.6	3.0	
20		7.8	5.2	3.9	3.1	2.6	
22		7.0	4.7	3.5	2.8	2.3	
24		6.6	4.3	3.2	2.6	2.1	
		12-INCH-DIAMETER STRINGER					
8		37.2	24.9	18.7	14.9	12.4	
10		29.9	19.8	15.0	11.9	9.9	
12		24.9	16.6	12.4	9.9	8.3	
14		20.3	13.5	10.1	8.1	6.8	
16		17.8	11.8	8.9	7.1	5.9	
18		15.8	10.8	7.9	6.3	5.2	
20		13.4	8.9	6.7	5.3	4.5	
22		21.2	8.1	6.1	4.9	4.0	

24	11.2	7.5	5.6	4.5	3.8
26	9.7	6.5	4.9	3.9	3.2
28	9.1	6.0	4.5	3.6	3.0
30	8.5	5.6	4.2	3.4	2.8

14-INCH-DIAMETER STRINGER

8	39.6	29.7	23.7	19.8	14.7
10	31.7	23.7	19.0	15.8	13.5
12	26.4	19.8	15.8	13.2	11.3
14	21.5	16.1	12.9	10.7	9.2
16	18.8	14.1	11.3	9.4	8.1
18	16.7	12.5	10.0	8.4	7.2
20	14.3	10.7	8.6	7.1	6.1
22	13.0	9.7	7.8	6.5	5.6
24	11.9	8.9	7.1	5.9	5.1
26	10.4	7.8	6.2	5.2	4.4
28	9.6	7.2	5.8	4.8	4.1
30	9.0	6.7	5.4	4.5	3.8

16-INCH-DIAMETER STRINGER

8	59.0	44.3	35.4	29.6	25.3
10	47.3	35.4	28.4	23.6	20.3
12	39.4	29.5	23.6	19.7	16.9
14	32.1	24.1	19.3	16.0	13.7
16	28.1	21.1	16.8	14.0	12.0
18	25.0	18.7	15.0	12.5	10.7
20	21.3	16.0	12.7	10.6	9.1
22	19.3	14.5	11.6	9.7	8.3
24	17.7	13.3	10.6	8.9	7.6
26	15.5	11.6	9.3	7.7	6.3
28	14.3	10.7	8.6	7.2	6.1
30	13.4	10.0	8.1	6.7	5.7

- Notes: (1) Values based on red or white oak, pine, cedar or hickory. For yellow-popular reduce values by 20 percent.
- (2) Table values are in tons, assuming 3-inch by 12-inch floor planks and 3-inch run planks in good condition or 2-inch by 4-inch solid laminated deck without run planks.
- (3) For plank-floor bridges without run planks reduce capacity by 20 percent.
- (4) Diameter is at midspan of stringer.

Span (ft)	12" x 12" (lb)	12" x 14" (lb)	12" x 16" (lb)	12" x 18" (lb)	12" x 20" (lb)
10	1.2	1.5	1.8	2.1	2.4
12	1.5	1.8	2.1	2.4	2.7
14	1.8	2.1	2.4	2.7	3.0
16	2.1	2.4	2.7	3.0	3.3
18	2.4	2.7	3.0	3.3	3.6
20	2.7	3.0	3.3	3.6	3.9
22	3.0	3.3	3.6	3.9	4.2
24	3.3	3.6	3.9	4.2	4.5
26	3.6	3.9	4.2	4.5	4.8
28	3.9	4.2	4.5	4.8	5.1
30	4.2	4.5	4.8	5.1	5.4
32	4.5	4.8	5.1	5.4	5.7
34	4.8	5.1	5.4	5.7	6.0
36	5.1	5.4	5.7	6.0	6.3
38	5.4	5.7	6.0	6.3	6.6
40	5.7	6.0	6.3	6.6	6.9
42	6.0	6.3	6.6	6.9	7.2
44	6.3	6.6	6.9	7.2	7.5
46	6.6	6.9	7.2	7.5	7.8
48	6.9	7.2	7.5	7.8	8.1
50	7.2	7.5	7.8	8.1	8.4
52	7.5	7.8	8.1	8.4	8.7
54	7.8	8.1	8.4	8.7	9.0
56	8.1	8.4	8.7	9.0	9.3
58	8.4	8.7	9.0	9.3	9.6
60	8.7	9.0	9.3	9.6	9.9
62	9.0	9.3	9.6	9.9	10.2
64	9.3	9.6	9.9	10.2	10.5
66	9.6	9.9	10.2	10.5	10.8
68	9.9	10.2	10.5	10.8	11.1
70	10.2	10.5	10.8	11.1	11.4
72	10.5	10.8	11.1	11.4	11.7
74	10.8	11.1	11.4	11.7	12.0
76	11.1	11.4	11.7	12.0	12.3
78	11.4	11.7	12.0	12.3	12.6
80	11.7	12.0	12.3	12.6	12.9
82	12.0	12.3	12.6	12.9	13.2
84	12.3	12.6	12.9	13.2	13.5
86	12.6	12.9	13.2	13.5	13.8
88	12.9	13.2	13.5	13.8	14.1
90	13.2	13.5	13.8	14.1	14.4
92	13.5	13.8	14.1	14.4	14.7
94	13.8	14.1	14.4	14.7	15.0
96	14.1	14.4	14.7	15.0	15.3
98	14.4	14.7	15.0	15.3	15.6
100	14.7	15.0	15.3	15.6	15.9

CRITERIA
FOR MULCHING AND
FINAL STABILIZATION

Definition

Establishing vegetation on erodible segments of truck haul roads, skid trails, landings or other disturbed areas resulting from forest harvest operations.

Purpose

To stabilize disturbed soil and to reduce damages from sediment and runoff to adjacent land and watercourses.

Seeding

1. Soil Preparation: Water diversion structures such as water bars, culverts and broad based dips, must be made operative before stabilization is initiated.
2. Because of soil compaction from equipment traffic seedbeds should be loosened to a minimum depth of 3 inches.
3. Lime and fertilizer should be thoroughly harrowed or disced into the seedbed.
 - a. Lime to a pH of 6.0, or in the absence of a soil test, apply a minimum rate of 2 tons per acre.
 - b. Fertilize at the minimum rate of 1,000 pounds of 10-10-10 per acre.
4. Seedbed preparation is a critical aspect of establishing vegetative cover and procedures should be adhered to as closely as possible.
5. Use the seeding and area determination tables (page 32 and 33) to determine acreage, seed mixtures, application rates and seeding date. When harvests are conducted during winter months, seed should still be applied under the mulch. The seed will germinate in the spring.

6. A cyclone seeder is adequate for sowing seed. Apply seed uniformly over a moist seedbed.
7. Seeded areas should be closed off from all use until plants are adequately established.

Mulching Specifications

1. Straw is used effectively as mulch on forest harvest operations. Natural forest leaf litter may also be applied as mulch for very small areas.
2. Wood chips may not be used as mulch for seeding.
3. Straw should be applied at the rate of 1 1/2 to 2 tons per acre or 70 to 90 pounds (two bales) per 1,000 square feet.

Maintenance

1. Inspect all seeded areas for failures and make necessary repairs and reseedings within the planting season.
2. If stand is inadequate for erosion control, over-seed and fertilize using half the original rates.
3. If stand is over 60% damaged, re-establish following original specifications.
4. Seeded areas must be protected from grazing and vehicle damage until plants are well established.
5. All drainage structures must function properly.

AREA DETERMINATION TABLE

IN ACRES

Number of Feet	Width				
	8'	10'	12'	14'	18'
50	.01	.01	.01	.02	.02
100	.02	.02	.03	.03	.04
250	.05	.06	.07	.08	.10
500	.09	.12	.14	.16	.21
750	.14	.17	.21	.24	.31
1,000	.18	.14	.28	.32	.41
1,500	.28	.34	.41	.48	.62
2,000	.36	.48	.56	.64	.83
5,000	.92	1.15	1.38	1.61	2.07
5,280	.97	1.21	1.45	1.70	2.18

To determine pounds of seed required for a given width and length, multiply the appropriate acre figures above times the pounds/acre as recommended in the following suggested seeding mixtures table.

To determine acreage of other areas such as loading decks, turnouts, etc. use the following formula:

$$\text{Ave. length} \times \text{Ave. width} = \text{Sq. ft.}$$

$$\text{Sq. ft. divided by } 43,000 = \text{acres.}$$

Multiply the answer times the pounds/acre as recommended in TABLE (page 33).

Example: A landing is 50 feet long by 60 feet wide. The area would be 50 x 40 = 2,000 sq. ft. 2,000 divide 43,000 = 0.46 acres.

SUGGESTED SEEDING MIXTURES, RATES AND DATES

MIX NO.	SEED MIXTURES	SEEDING RATE		OPTIMUM SEEDING DATES		
		LBS/ ACRE	LBS/ 1000 SQ FT	COASTAL PLAIN	PIEDMONT	MOUNTAINS
1	Kentucky 31					
	Tall Fescue	35	0.8			
	Creeping Red Fescue	35	0.8			
	Red Clover	2	.1	2/1-6/1		
	Total Mix	72	1.7	8/15-10/31	3/1-10/15	3/1-10/1
2	Kentucky 31					
	Tall Fescue	35	0.8			
	Creeping Red Fescue	35	0.8			
	Red Clover	2	.1			
	Weeping Lovegrass	2	.1			
	Total Mix	74	1.8	6/1-8/15		
3	Kentucky 31			2/1-6/1		
	Tall Fescue*	70	1.6	8/15-10/31	3/1-10/15	3/1-10/1
4	Kentucky 31					
	Tall Fescue	40	.9			
	Reed Canarygrass	20	.5			
	Total Mix	60	1.4	2/1-10/31	3/1-10/15	3/1-10/1

*K-31 Often contains a fungus which is toxic to certain wildlife, such as rabbits. For wildlife enhancement an endophyte free tall fescue should be used instead of K-31. Assistance in selecting other plant species which will be beneficial to wildlife may be obtained from the Maryland Forest, Park and Wildlife Service.

Mix No. 1 is to be used on most logging roads and trails where some shade is present.

Mix No. 2 is to be used during hot, dry periods of summer.

Mix No. 3 is to be used in sunny areas without shade. During hot dry periods of summer, add 2 lbs/acre of Weeping Lovegrass.

Mix No. 4 is to be used in areas where wet, poorly drained soils are encountered.

Note: The above dates list optimum times for seed germination. Seed should still be sown, however, when logging operations are completed during winter months. The seed will germinate in the Spring.

APPENDIX 1
SOIL CONSERVATION DISTRICT (SCD) OFFICES
FOR EACH MARYLAND COUNTY

Allegany SCD
11602 Bedford Road, NE
Cumberland MD 21502
(301) 777-1747

Anne Arundel SCD
Heritage Office Center
2662 Riva Road
Annapolis MD 21401
(410) 222-7822

Baltimore County SCD
9811 Van Buren Lane
Cockeysville MD 21030
(410) 666-1188

Calvert SCD
65 Duke Street, P.O. Box 657
Prince Frederick MD 20678
(410) 535-1521

Caroline SCD
640 Legion Road, Unit 3
Denton MD 21629
(410) 876-0499

Carroll SCD
1004 Littlestown Pike
Westminster MD 21157
(410) 876-0499

Cecil SCD
Upper Chesapeake Corp. Ctr.
101 Chesapeake Blvd., A-3
Elkton MD 21921
(410) 398-2482

Charles SCD
101 Catalapa Drive
La Plata MD 20646
(301) 934-9590

Dorchester SCD
501 Court Lane
Cambridge MD 21613
(410) 228-1323

Frederick SCD
92 Thomas Johnson Drive
Frederick MD 21702
(301) 695-2803

Garrett SCD
203 S. Fourth Street
Oakland MD 21550
(301) 334-1900

Harford SCD
1208 Churchville Road
Bel Air MD 21014
(410) 838-6181

Howard SCD
9025 Chevrolet Drive, Suite J
Ellicott City MD 21042
(410) 465-3180

Kent SCD
122-4 Speer Road
Chestertown MD 21620
(410) 778-5150

Montgomery SCD
18410 Muncaster Road
Derwood MD 20855
(301) 590-2855

Prince George's SCD
14741 Gov. Oden Bowie Drive
Upper Marlboro MD 20772
(301) 952-3930

Queen Anne's SCD
Route 2, Box 292
Centreville MD 21617
(410) 758-3136

St. Mary's SCD
P. O. Box 810
Leonardtown MD 20650
(301) 475-8402

Somerset SCD
30730 Park Drive
Princess Anne MD 21853
(410) 651-0390

Talbot SCD
215 Bay Street
Easton MD 21601
(410) 822-1577

Washington SCD
1260 Maryland Avenue
Hagerstown MD 21740
(301) 797-6820

Wicomico SCD
2322 B Goddard Pkwy.
Salisbury MD 21801
(410) 546-4731

Worcester SCD
200 Bank Street, P.O. Box 907
Snow Hill MD 21863
(410) 632-1993

FOR PUBLIC LAND PLAN APPROVAL

Department of the Environment
Water Management Administration
Sediment and Stormwater Plan Review
2500 Broening Highway
Baltimore, Maryland 21224
(410) 631-3563

FOR STREAM CROSSING PERMITS

Department of Natural Resources
Water Resources Administration
Tawes State Office Building
580 Taylor Avenue
Annapolis, Maryland 21401
(410) 974-2265

FOR WETLAND PERMITS

Department of Natural Resources
Water Resources Administration
Tawes State Office Building
580 Taylor Avenue
Annapolis, Maryland 21401
(410) 974-3872

APPENDIX 2
STATE OF MARYLAND FORESTRY OFFICES
FORESTERS' OFFICE

Western Region

Regional Forester
3 Pershing Street, Rm. 101
Cumberland, MD 21502
(301) 777-2137

Garrett County
Project Forester
Route 1, Box 305A
Oakland, MD 21550
(301) 334-3296

Allegany County
Project Forester
3 Pershing Street, Room 101
Cumberland, MD 21502
(301) 777-2137

Washington County
Project Forester
Route 2, Box 173
Clear Spring, MD 21722
(301) 791-4733

Frederick County
Project Forester
8602 Gambrill Park Road
Frederick, MD 21701
(410) 438-8417

Southern Region

Regional Forester
Huntington Community Center
Box 116
West Bowie, MD 20719
(301) 464-3065

Howard and Montgomery Counties
Project Forester
17400 Annapolis Rock Road
Woodbine, MD 21797
(410) 442-2080

Prince George's and Northern Anne Arundel Counties
Project Forester
Huntington Community Center
Box 116
West Bowie, MD 20719
(301) 464-3065

Calvert and Southern Anne Arundel Counties
Project Forester
P.O. Box 1136
Prince Frederick, MD 20678
(410) 535-1303

St. Mary's County
Project Forester
Court Square Building
P.O. Box 385
Leonardtwn, MD 20650
(301) 475-8551

Charles County
Project Forester
Doncaster Demonstration Forest
Route 1, Box 425
Indian Head, MD 20640
(301) 934-2282

Eastern Region

Regional Forester
201 Baptist Street
Salisbury, MD 21801
(410) 543-6745

Caroline and Talbot Counties
Project Forester
Martinak State Park
Deep Shore Road
Denton, MD 21629
(410) 479-1619

Dorchester County
Project Forester
Star Route, Box 605
Church Creek, MD 21622
(410) 228-1861

Wicomico County
Project Forester
Powellville Work Center
Route 1, Box 136
Parsonsbuurg, MD 21849
(410) 835-8686

Worcester County
Project Forester
Nassawango Work Center
Route 2, Box 106
Pocomoke City, MD 21863
(410) 632-1955

Somerset County
Project Forester
Highway Admin. Maintenance Facility
P.O. Box 387
Princess Anne, MD 21853
(410) 651-2009

Central Region

Regional Forester
2 Bond Street
Bel Air, MD 21014
(410) 836-4550

Carroll County
Project Forester
133 E. Main Street
Westminster, MD 21157
(410) 848-9290

Baltimore County
Project Forester
9405 Old Harford Road
Baltimore, MD 21234
(410) 665-5820

Harford County
Project Forester
2 Bond Street
Bel Air, MD 21014
(410) 836-4550

Cecil County
Project Forester
Black Hill Station
130 McKinneytown Road
North East, MD 21901
(410) 287-2918

Kent and Queen Anne's Counties
Project Forester
120 Broadway Avenue, Room 207
Centreville, MD 21617
(410) 758-2321

State Forests

Potomac-Garrett State Forest
Forest Manager
Route 3, Box 9305
Deer Park, MD 21550
(301) 334-2038

Savage River State Forest
Forest Manager
New Germany State Park
Route 2, Box A63
Grantsville, MD 21536
(301) 895-5759

Green Ridge State Forest
Forest Manager
Star Route
Flintstone, MD 21530
(301) 777-2345

Elk Neck State Forest
Contact Cecil County Project Forester
(410) 287-2918

Cedarville State Forest
Route 4, Box 106-A
Brandywine, MD 20613
(301) 888-1622

Doncaster State Forest
Contact Project Forester
(301) 934-2282

Seth State Forest
Contact Caroline/Talbot Project Forester
(410) 479-1619

Wicomico State Forest
Contact Wicomico County Project Forester
(410) 835-8686

Pocomoke State Forest
Forest Manager
Pocomoke River State Park
Route 3, Box 237
Snow Hill, MD 21863
(410) 632-2566

APPENDIX 3
SAMPLE PLAN MODIFICATION

The following is an example of the type of information which is necessary for a plan modification. This modification would need to be approved by the soil conservation district and attached to the standard plan.

PLAN AMENDMENT FOR PROPOSED JOHNSON RIDGE PULPWOOD HARVEST
Prepared By: Horace Honeysuckle, State Forester

The topography surrounding Johnson Ridge is such that it is not possible to construct an access road which does not exceed 15 percent. It will be necessary, therefore, to construct a road which will have a twenty percent grade at one location. It will also be necessary to place a six-foot fill in one location for the road construction. The remainder of the road will follow the specifications listed in the Standard Plan.

The location of the twenty percent road grade and the six-foot fill are identified on the map. Sediment control at each location will be maintained as follows:

Twenty percent grade location:

This section of straight road will be 250 feet long. To divert excess water from the road, broad based dips will be installed according to specifications. Using the formula listed in the specifications, 2 dips will be equally spaced along the road. Because of the steep slopes adjacent to the road, riprap stone will be placed at the discharge point of each dip. The riprap will extend fifteen feet from the road, so as to dissipate the energy of flowing water. All road side slopes which are exposed during construction will be immediately seeded and mulched. At the completion of the harvest this section of the road will be backdragged seeded and mulched.

Fill Location

This area shows as a dashed blue line on the USGS Topo maps. As the drainage area above this point is only 65 acres, a stream crossing permit is not required. However, to prevent water from backing up behind the fill a permanent culvert will be installed. According to the specifications, a 30 inch culvert will be required. After culvert installation, the roadbed will be constructed with 3:1 slopes and immediately stabilized with seed and mulch. A straw bale dike will be installed at the toe of the slope to prevent sedimentation of the watercourse.

APPENDIX 4
CALCULATING STREAM CROSS SECTIONAL AREA

A. A hypothetical stream channel may be viewed as follows:

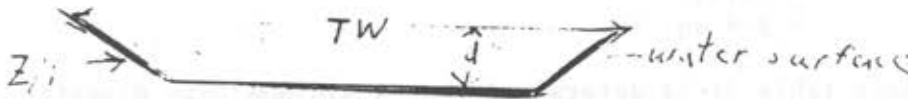

Where: TW = Top Width of the channel
 d = Depth of the channel
 Z/1 = Side Slope of the channel (e.g., 2:1)
 XA = Cross Sectional Area

B. The cross sectional area (XA) of a stream channel is calculated from the following formula:

$$XA = TW(d) - Z(d^2)$$

$$60 \text{ percent of } XA = .6 [TW(d) - Z(d^2)]$$

C. Stream channels in Garrett, Allegany, and Washington Counties tend to have vertical side slopes, therefore:

$$XA = TW[d]$$

$$60 \text{ percent of } XA = .6 [TW(d)]$$

D. Stream channels elsewhere tend to have a 2:1 side slope, therefore:

$$XA = .6 [TW(d) - 2(d^2)]$$

E. Cross sectional areas of standard pipe sizes are as follows:

<u>Pipe Size (inches)</u>	<u>Cross-Sectional Area (square feet)</u>
12	0.79
15	1.23
18	1.77
21	2.41
24	3.14
27	3.97
30	4.91
33	5.94
36	7.07
42	9.62
48	12.57
54	15.90
60	19.64

Cross sectional areas over 19.6 square feet require more individual design analysis.

F. Example

1. A stream channel in Calvert County is determined to have a top width (TW) of 6 feet and a depth (d) of 2 feet at the proposed crossing site.

$$\begin{aligned} 60 \text{ percent of } XA &= .6[6(2) - 2(2^2)] \\ &= .6[12 - 8] \\ &= .6[4] \\ &= 2.4 \text{ sq. ft.} \end{aligned}$$

From the above table it is determined that a minimum pipe diameter of 21 inches is required.

2. A stream channel in Garrett County is determined to have a top width (TW) of 8 feet and a depth of 2.5 feet at the proposed crossing site.

$$\begin{aligned} 60 \text{ percent of } XA &= .6[8(2.5)] \\ &= .6[20] \\ &= 12 \text{ sq. ft.} \end{aligned}$$

This crossing requires a 48 inch pipe.