



U.S. Fish & Wildlife Service

Adaptive Harvest Management

2025 Hunting Season



PREFACE

The process of setting waterfowl hunting regulations is conducted annually in the United States (U.S.; Blohm 1989) and involves a number of meetings where the status of waterfowl is reviewed by the agencies responsible for setting hunting regulations. In addition, the U.S. Fish and Wildlife Service (USFWS) publishes proposed regulations in the Federal Register to allow public comment. This document is part of a series of reports intended to support development of harvest regulations for the 2025 hunting season (Appendix A). Specifically, this report is intended to provide waterfowl managers and the public with information about the use of adaptive harvest management (AHM) for setting waterfowl hunting regulations in the U.S. This report provides the most current data, analyses, and decision-making protocols. However, adaptive management is a dynamic process and some information presented in this report will differ from that in previous reports.

Citation: U.S. Fish and Wildlife Service. 2024. Adaptive Harvest Management: 2025 Hunting Season. U.S. Department of Interior, Washington, D.C. 84 pp. Available online at <https://fws.gov/project/adaptive-harvest-management>

This report contains annual estimates of waterfowl abundance, harvest rates, and optimal regulatory strategies. Due to an extensive volume of data encompassing multiple years and geographic areas, data tables may be large and complex. Readers that may need help reading and interpreting the data, or that may need data presented in an alternative format to facilitate reading and interpretation, should contact the author at scott_boomer@fws.gov.

ACKNOWLEDGEMENTS

A Harvest Management Working Group (HMWG) comprised of representatives from the USFWS, the U.S. Geological Survey (USGS), the Canadian Wildlife Service (CWS), and the four Flyway Councils (Appendix B) was established in 1992 to review the scientific basis for managing waterfowl harvests. The working group, supported by technical experts from the waterfowl management and research communities, subsequently proposed a framework for adaptive harvest management, which was first implemented in 1995. The USFWS expresses its gratitude to the HMWG and to the many other individuals, organizations, and agencies that have contributed to the development and implementation of AHM.

We are grateful for the continuing technical support from our USGS colleagues: M. C. Runge, J. A. Hostetler, M. Rogosky, and J. A. Royle. We are also grateful to D. Ziolkowski Jr. and M. Lutmerding of the USGS Eastern Ecological Science Center North American Breeding Bird Survey (BBS), and the thousands of USGS BBS participants for providing wood duck data in an expedited manner. Please note that information provided by USGS in this report has not received the Director's approval and, as such, is provisional and subject to revision. In addition, we acknowledge that the use of trade, firm, or product names does not imply endorsement by these agencies.

This report was prepared by the USFWS Division of Migratory Bird Management. G. S. Boomer, J. M. Yeiser, and G. S. Zimmerman were the principal authors. Individuals that provided essential information or otherwise assisted with report preparation included: N. Zimpfer, F. Rivera, P. K. Devers, K. Fleming, R. Raftovich, G. Fleming (USFWS), and M. Gendron (CWS). Comments regarding this document should be sent to the Chief, Division of Migratory Bird Management, U.S. Fish & Wildlife Service Headquarters, MS: MB, 5275 Leesburg Pike, Falls Church, VA 22041-3803.

Cover art: The 2024–2025 Federal Duck Stamp featuring a northern pintail (*Anas acuta*) painted by Chuck Black from Belgrade, Montana.

TABLE OF CONTENTS

1 EXECUTIVE SUMMARY	7
2 BACKGROUND	9
3 ADJUSTMENTS FOR THE 2025 REGULATORY PROCESS	10
4 WATERFOWL STOCKS AND FLYWAY MANAGEMENT	10
5 WATERFOWL POPULATION DYNAMICS	12
5.1 Mid-Continent Mallard Stock	12
5.2 Western Mallard Stock	12
5.3 Atlantic Flyway Multi-Stock	14
6 HARVEST-MANAGEMENT OBJECTIVES	15
7 REGULATORY ALTERNATIVES	16
7.1 Evolution of Alternatives	16
7.2 Regulation-Specific Harvest Rates	16
8 OPTIMAL REGULATORY STRATEGIES	19
9 APPLICATION OF ADAPTIVE HARVEST MANAGEMENT TO OTHER STOCKS	24
9.1 American Black Duck	24
9.2 Northern Pintails	28
9.3 Scaup	31
9.4 Eastern Mallards	32
10 EMERGING ISSUES IN ADAPTIVE HARVEST MANAGEMENT	34
LITERATURE CITED	36
Appendix A 2024-2025 Regulatory Schedule	41
Appendix B Harvest Management Working Group Members	42
Appendix C Proposed Fiscal Year 2025 Harvest Management Working Group Priorities	45
Appendix D Mid-Continent Mallard Models	46
Appendix E Western Mallard Models	50
Appendix F Atlantic Flyway Multi-Stock Models	57
Appendix G Modeling Waterfowl Harvest Rates	61
Appendix H Northern Pintail Models	68
Appendix I Scaup Model	80

LIST OF FIGURES

1	Waterfowl Breeding Population and Habitat Survey (WBPHS) strata and state, provincial, and territorial survey areas currently assigned to the mid-continent and western stocks of mallards and eastern waterfowl stocks for the purposes of adaptive harvest management.	11
2	Population estimates of mid-continent mallards observed in the WBPHS (strata: 13–18, 20–50, and 75–77) and the Great Lakes region (Michigan, Minnesota, and Wisconsin) from 1992–2024.	13
3	Population estimates of mid-continent mallards observed from the WBPHS compared to mid-continent mallard integrated population model (IPM) predictions from 1974–2024.	13
4	Population estimates of western mallards observed in Alaska (WBPHS strata 1–12) and the southern Pacific Flyway (California, Oregon, Washington, and British Columbia combined) from 1990 to 2024.	14
5	Population estimates of American green-winged teal (AGWT), wood ducks (WODU), ring-necked ducks (RNDU), and goldeneyes (GOLD) observed in eastern Canada (WBPHS strata 51–53, 56, 62–72) and the U.S. (Atlantic Flyway states) from 1998 to 2024.	15
6	Mid-continent mallard pre-survey harvest policies derived with current regulatory alternatives (including the closed-season constraint), updated mid-continent mallard model parameter estimates, and an objective of maximizing long-term cumulative harvest.	21
7	Western mallard pre-survey harvest policies derived with current regulatory alternatives, updated (1990–2024) western mallard population models and parameter estimates, and an objective to maximize long-term cumulative harvest.	21
8	Atlantic Flyway multi-stock pre-survey harvest policies derived with current regulatory alternatives, updated (1998–2024) population models and parameter estimates, and an objective to achieve 98% of the maximum, long-term cumulative harvest of the aggregate stocks.	23
9	Functional form of the harvest parity constraint designed to allocate allowable black duck harvest equally between the U.S. and Canada.	25
10	Updated reporting rates for bands with 1-800 number and web address inscriptions used to estimate black duck harvest rates.	26
11	Predictive harvest rate distributions for adult male black ducks expected under the application of the current regulatory alternatives in Canada (left) and the U.S. (right).	27
12	Median estimates of the black duck harvest additivity ($a1$) parameter over time.	28
A.1	Schedule of biological information availability, regulation meetings, and Federal Register publications for the 2025–2026 hunting season.	41
G.1	Updated reporting rates by region of recovery (AF = Atlantic Flyway, ECAN = eastern Canada, MF = Mississippi Flyway) and hunting season.	65
H.1	A diagram that describes the population model developed to represent annual pintail population dynamics.	69
H.2	Yield curve for the continental, northern pintail population, under two scenarios of mean settling latitude.	77

LIST OF TABLES

1	Current regulatory alternatives for the duck-hunting season.	17
2	Predictions of harvest rates of adult male, mid-continent and western mallards expected with application of the current regulatory alternatives in the Mississippi, Central, and Pacific Flyways.	18
3	Predictions of harvest rates of American green-winged teal (AGWT), wood ducks (WODU), ring-necked ducks (RNDU), and goldeneyes (GOLD) expected under closed, restrictive, moderate, and liberal regulations in the Atlantic Flyway.	19
4	Optimal regulatory strategy for the Mississippi and Central Flyways for the 2025 hunting season.	22
5	Optimal regulatory strategy for the Pacific Flyway for the 2025 hunting season.	23
6	Optimal regulatory strategy for the Atlantic Flyway for the 2025 hunting season.	24
7	Black duck optimal regulatory strategies for Canada and the United States for the 2025 hunting season.	29
8	Northern pintail optimal regulatory strategy for the 2025 hunting season.	30
9	Regulatory alternatives and total expected harvest levels corresponding to the closed, restrictive, moderate, and liberal packages considered in the scaup adaptive harvest management decision framework.	31
10	Scaup optimal regulatory strategy for the 2025 hunting season.	33
11	Eastern mallard optimal regulatory strategy for the Atlantic Flyway for the 2025 hunting season.	35
C.1	Priority rankings and project leads identified for the technical work proposed at the 2023 Harvest Management Working Group meeting and updated during the summer of 2024.	45
D.1	Estimates (N) and associated standard errors (SE) of mid-continent mallards (in millions) observed in the WBPHS (strata 13–18, 20–50, and 75–77) and the Great Lakes region (Michigan, Minnesota, and Wisconsin) 1992–2024.	47
D.2	Survival parameter estimates (logit scale) resulting from the mid-continent mallard IPM.	48
E.1	Estimates (N) and associated standard errors (SE) of western mallards (in millions) observed in Alaska (WBPHS strata 1–12) and the southern Pacific Flyway (California, Oregon, Washington, and British Columbia combined) from 1990–2024.	50
E.2	Estimates of model parameters resulting from fitting a discrete logistic model to a time series of estimated population sizes and harvest rates of mallards breeding in Alaska from 1990–2024.	54
E.3	Estimates of model parameters resulting from fitting a discrete logistic model to a time series of estimated population sizes and harvest rates of mallards breeding in the southern Pacific Flyway (California, Oregon, Washington, and British Columbia combined) from 1992–2024.	55
F.1	Estimates (N in millions) and associated standard errors (SE) of American green-winged teal (AGWT), wood ducks (WODU), ring-necked ducks (RNDU), and goldeneyes (GOLD) observed in eastern Canada (WBPHS strata 51–53, 56, 62–72) and the U.S. (Atlantic Flyway states) from 1998–2024.	57
F.2	Estimates of model parameters resulting from fitting a discrete logistic model to a time series of estimated population sizes and harvest rates of American green-winged teal (AGWT), wood ducks (WODU), ring-necked ducks (RNDU), and goldeneyes (GOLD) breeding in eastern Canada and the U.S. from 1998–2024.	59
F.3	Lognormal mean and standard deviations (SD) used to describe the prior distributions for maximum intrinsic growth rate (r) for American green-winged teal (AGWT), wood ducks (WODU), ring-necked ducks (RNDU), and goldeneyes (GOLD) in eastern Canada and U.S.	60
G.1	Parameter estimates for predicting mid-continent mallard harvest rates resulting from a hierarchical, Bayesian analysis of mid-continent mallard band-recovery information from 1998–2023.	63
G.2	Parameter estimates for predicting western mallard harvest rates resulting from a hierarchical, Bayesian analysis of western mallard band-recovery information from 2008–2023.	64
G.3	Annual harvest rate estimates (h) and associated standard errors (SE) for American green-winged teal (AGWT), wood ducks (WODU), ring-necked ducks (RNDU), and goldeneyes (GOLD) in eastern Canada (WBPHS strata 51–53, 56, 62–72) and the U.S. (Atlantic Flyway states) from 1998–2023.	66
G.4	Parameter estimates for predicting American green-winged teal (AGWT), wood duck (WODU), ring-necked duck (RNDU), and goldeneye (GOLD) expected harvest rates for season lengths < 60 days and bag limits < 6 birds.	67
H.1	Summary of posterior statistics for the scaling parameters estimated with the pintail IPM.	75
H.2	Summary of posterior statistics for the recruitment parameters estimated with the pintail IPM.	75
H.3	Summary of posterior statistics for the survival sub-model parameters estimated with the pintail IPM.	76

H.4	Expected recoveries of pre-season banded birds involving both solicited and unsolicited band reporting.	78
H.5	Prior distributions of population parameters specified in a Bayesian estimation framework for the pintail IPM.	79
I.1	Model parameter estimates resulting from a Bayesian analysis of scaup breeding population observations from 1974–2024, along with harvest and banding information from 1974–2023.	83

1 EXECUTIVE SUMMARY

In 1995 the U.S. Fish and Wildlife Service (USFWS) implemented the adaptive harvest management (AHM) program for setting duck hunting regulations in the United States (U.S.). The AHM approach provides a framework for making objective decisions in the face of incomplete knowledge concerning waterfowl population dynamics and regulatory impacts.

Current AHM protocols are based on the population dynamics and status of two mallard (*Anas platyrhynchos*) stocks and a suite of waterfowl stocks in the Atlantic Flyway. Mid-continent mallards are defined as those breeding in the WBPHS strata 13–18, 20–50, and 75–77 plus mallards breeding in the states of Michigan, Minnesota, and Wisconsin (state surveys). The prescribed regulatory alternative for the Mississippi and Central Flyways depends exclusively on the status of these mallards. Western mallards are defined as those breeding in WBPHS strata 1–12 (hereafter Alaska) and in the states of California, Oregon, Washington, and the Canadian province of British Columbia (hereafter southern Pacific Flyway). The prescribed regulatory alternative for the Pacific Flyway depends exclusively on the status of these mallards. The Atlantic Flyway multi-stock AHM protocol recognizes 4 populations of eastern waterfowl [American green-winged teal (*Anas crecca*), wood ducks (*Aix sponsa*), ring-necked ducks (*Aythya collaris*), and goldeneyes (both *Bucephala clangula* and *B. islandica* combined)]. The regulatory choice for the Atlantic Flyway depends exclusively on the status of these waterfowl populations.

Waterfowl population models are based on the best available information and account for uncertainty in population dynamics and the impact of harvest. For each stock, key demographic parameters are updated each year with Bayesian, integrated population modeling estimation frameworks to predict mid-continent mallard, western mallard, and eastern waterfowl population dynamics. These parameters and corresponding measures of uncertainty are then used in independent optimization frameworks to derive stock-specific optimal harvest policies.

For the 2025 hunting season, the USFWS is considering similar regulatory alternatives as 2024. The nature of the restrictive, moderate, and liberal alternatives has remained essentially unchanged since 1997, except that extended framework dates have been offered in the moderate and liberal alternatives since 2002. Harvest rates associated with each of the regulatory alternatives have been updated based on band-recovery data from pre-season banded birds. The expected harvest rates of adult males under liberal hunting seasons are 0.11, and 0.14 for mid-continent and western mallards, respectively. In the Atlantic Flyway, expected harvest rates under the liberal alternative are 0.11, 0.12, 0.13, and 0.03 for American green-winged teal, wood ducks, ring-necked ducks, and goldeneyes, respectively.

Optimal regulatory strategies for the 2025 hunting season were calculated using: (1) harvest-management objectives specific to each stock; (2) current regulatory alternatives; and (3) current population models and updated parameter estimates. Based on liberal regulatory alternatives selected for the 2024 hunting season, the 2024 survey results of 6.61 million mid-continent mallards, 5.16 million total ponds, 0.94 million western mallards (0.51 million in Alaska and 0.43 million in the southern Pacific Flyway), 0.87 million wood ducks, 0.47 million American green-winged teal, 0.73 million ring-necked ducks, and 1.20 million goldeneyes observed in the eastern survey area and Atlantic Flyway, the optimal choice for the 2025 hunting season in all four Flyways is the liberal regulatory alternative.

AHM concepts and tools have been successfully applied toward the development of formal adaptive harvest management protocols that inform American black duck (*Anas rubripes*), northern pintail (*Anas acuta*), scaup (*Aythya affinis*, *A. marila* combined), and eastern mallard harvest decisions.

For black ducks, the optimal country-specific regulatory strategies for the 2025 hunting season were calculated using: (1) an objective to achieve 98% of the maximum, long-term cumulative harvest; (2) current country-specific black duck regulatory alternatives; and (3) updated model parameters and weights. Based on a liberal regulatory alternative selected by Canada and a moderate regulatory alternative selected by the U.S. for the 2024 hunting season, and 0.86 million breeding black ducks estimated in eastern Canada, the optimal regulatory choices for the 2025 hunting season are the liberal regulatory alternative in Canada and the moderate regulatory alternative in the United States.

After several years of analysis and development by the Pintail Working Group, a new interim strategy for pintail harvest management is being implemented for the 2025 hunting season. For pintails, the optimal regulatory strategy for the 2025 hunting season was calculated using: (1) an objective of maximizing long-term cumulative harvest; (2) current pintail regulatory alternatives; and (3) a new integrated population model. Based on the 2024 survey results of

1.97 million pintails observed at a mean latitude of 57.02 degrees, the optimal regulatory choice for the 2025 hunting season for all four Flyways is the liberal regulatory alternative with a 3-bird daily bag limit.

For scaup, the optimal regulatory strategy for the 2025 hunting season was calculated using: (1) an objective to achieve 95% of the maximum, long-term cumulative harvest; (2) current scaup regulatory alternatives; and (3) updated model parameters and weights. Based on a restrictive regulatory alternative selected for the 2024 hunting season and the 2024 survey results of 4.07 million scaup, the optimal regulatory choice for the 2025 hunting season for all four Flyways is the restrictive regulatory alternative.

For eastern mallards, the optimal regulatory strategy for the 2025 hunting season was calculated using: (1) an objective to achieve 98% of the maximum, long-term cumulative harvest; (2) current eastern mallard regulatory alternatives; and (3) updated model parameters and weights. Based on the liberal regulatory alternative selected for the 2024 hunting season and the 2024 survey results of 1.17 million eastern mallards, the optimal regulatory choice for the 2025 hunting season for eastern mallards in the Atlantic Flyway is the liberal regulatory alternative.

2 BACKGROUND

The annual process of setting duck-hunting regulations in the U.S. is based on a system of resource monitoring, data analyses, and rule-making (Blohm 1989). Each year, monitoring activities such as aerial surveys, preseason banding, and hunter questionnaires provide information on population size, habitat conditions, and harvest levels. Data collected from these monitoring programs are analyzed each year, and proposals for duck-hunting regulations are developed by the Flyway Councils, States, and USFWS. After extensive public review, the USFWS announces regulatory guidelines within which States can set their hunting seasons.

In 1995, the USFWS adopted the concept of adaptive resource management (Walters 1986) for regulating duck harvests in the U.S. This approach explicitly recognizes that the consequences of hunting regulations cannot be predicted with certainty and provides a framework for making objective decisions in the face of that uncertainty (Williams and Johnson 1995). Inherent in the adaptive approach is an awareness that management performance can be maximized only if regulatory effects can be predicted reliably. Thus, adaptive management relies on an iterative cycle of monitoring, assessment, and decision-making to clarify the relationships among hunting regulations, harvests, and waterfowl abundance (Johnson et al. 2015).

In regulating waterfowl harvests, managers face four fundamental sources of uncertainty (Nichols et al. 1995a, Johnson et al. 1996, Williams et al. 1996):

- (1) environmental variation – the temporal and spatial variation in weather conditions and other key features of waterfowl habitat; an example is the annual change in the number of ponds in the Prairie Pothole Region, where water conditions influence duck reproductive success;
- (2) partial controllability – the ability of managers to control harvest only within limits; the harvest resulting from a particular set of hunting regulations cannot be predicted with certainty because of variation in weather conditions, timing of migration, hunter effort, and other factors;
- (3) partial observability – the ability to estimate key population attributes (e.g., population size, reproductive rate, harvest) only within the precision afforded by extant monitoring programs; and
- (4) structural uncertainty – an incomplete understanding of biological processes; a familiar example is the long-standing debate about whether harvest is additive to other sources of mortality or whether populations compensate for hunting losses through reduced natural mortality. Structural uncertainty increases contentiousness in the decision-making process and decreases the extent to which managers can meet long-term conservation goals.

AHM was developed as a systematic process for dealing objectively with these uncertainties. The key components of AHM include (Johnson et al. 1993, Williams and Johnson 1995):

- (1) a limited number of regulatory alternatives, which describe Flyway-specific season lengths, bag limits, and framework dates;
- (2) a set of population models describing various hypotheses about the effects of harvest and environmental factors on waterfowl abundance;
- (3) a measure of reliability (probability or “weight”) for each population model; and
- (4) a mathematical description of the objective(s) of harvest management (i.e., an “objective function”), by which alternative regulatory strategies can be compared.

These components are used in a stochastic optimization procedure to derive a regulatory strategy. A regulatory strategy specifies the optimal regulatory choice, with respect to the stated management objectives, for each possible combination of breeding population size, environmental conditions, and model weights (Johnson et al. 1997). The setting of annual hunting regulations then involves an iterative process:

- (1) each year, an optimal regulatory choice is identified based on resource and environmental conditions, and on current model weights;
- (2) after the regulatory decision is made, model-specific predictions for subsequent breeding population size are determined;
- (3) when monitoring data become available, model weights are increased to the extent that observations of population size agree with predictions, and decreased to the extent that they disagree; and
- (4) the new model weights and population parameter estimates are used to start another iteration of the process.

By iteratively updating model weights and optimizing regulatory choices, the process should eventually identify which model is the best overall predictor of changes in population abundance. The process is optimal in the sense that it provides the regulatory choice each year necessary to maximize management performance. It is adaptive in the sense that the harvest strategy “evolves” to account for new knowledge generated by a comparison of predicted and observed population sizes.

3 ADJUSTMENTS FOR THE 2025 REGULATORY PROCESS

The USFWS and their partners were able to perform the WBPHS and estimate waterfowl breeding populations as well as evaluate breeding habitat conditions in 2024, providing critical information necessary to update model weights and key population parameters that inform waterfowl AHM. We continue to use current system models to estimate 2020-2021 population sizes which were not observed due to the COVID-19 pandemic. These estimates are based on the most recent information from our monitoring programs, including harvest and harvest rate estimates observed during the 2020–21 hunting seasons. For some unobservable information (e.g., 2023 Canadian harvest estimates), we used formal time series analysis methods (Hyndman and Athanasopoulos 2018) to forecast these values.

After several years of extensive collaboration with the Pintail Working Group, a new interim AHM strategy is being implemented to inform northern pintail harvest regulations for the 2025 hunting season. This updated strategy is based on a new Integrated Population Model (IPM) that was developed by the Pintail Working Group to better represent pintail population and harvest dynamics (Appendix H).

For the 2025 regulatory process, technical changes were made to the estimation of Atlantic Flyway multi-stock harvest rates. We updated reporting rates used to adjust recovery probabilities for American green-winged teal and wood ducks, resulting in an updated time series of harvest rates and expected harvest rates under policy alternatives. More detail on these technical changes can be found in Appendix G.

4 WATERFOWL STOCKS AND FLYWAY MANAGEMENT

Since its inception, AHM has focused on the population dynamics and harvest potential of mallards, especially those breeding in mid-continent North America. Mallards constitute a large portion of the total U.S. duck harvest, and traditionally have been a reliable indicator of the status of many other species. Geographic differences in the reproduction, mortality, and migrations of waterfowl stocks suggest that there may be corresponding differences in optimal levels of sport harvest. The ability to regulate harvests of mallards originating from various breeding areas is complicated, however, by the fact that a large degree of mixing occurs during the hunting season. The challenge for managers, then, is to vary hunting regulations among Flyways in a manner that recognizes each Flyway’s unique breeding-ground derivation of waterfowl stocks. Of course, no Flyway receives waterfowl exclusively from one breeding area; therefore, Flyway-specific harvest strategies ideally should account for multiple breeding stocks that are exposed to a common harvest.

The optimization procedures used in AHM can account for breeding populations of waterfowl beyond the mid-continent region, and for the manner in which these ducks distribute themselves among the Flyways during the

hunting season. An optimal approach would allow for Flyway-specific regulatory strategies, which represent an average of the optimal harvest strategies for each contributing breeding stock weighted by the relative size of each stock in the fall flight. This joint optimization of multiple stocks requires: (1) models of population dynamics for all recognized stocks; (2) an objective function that accounts for harvest-management goals for all stocks in the aggregate; and (3) decision rules allowing Flyway-specific regulatory choices. At present, however, a joint optimization of western, mid-continent, and eastern stocks is not feasible due to computational hurdles. However, our preliminary analyses suggest that the lack of a joint optimization does not result in a significant decrease in management performance.

Currently, two stocks of mallards (mid-continent and western) and stocks of four different species of eastern waterfowl populations (Atlantic Flyway multi-stock; hereafter “multi-stock”) are recognized for the purposes of AHM and are used to establish overall duck frameworks for each Flyway (Figure 1). We use a constrained approach to the optimization of these stocks’ harvest, in which the regulatory strategy for the Mississippi and Central Flyways is based exclusively on the status of mid-continent mallards and the Pacific Flyway regulatory strategy is based exclusively on the status of western mallards. Historically, the Atlantic Flyway regulatory strategy was based exclusively on the status of eastern mallards. In 2018, the Atlantic Flyway and the USFWS adopted a multi-stock AHM framework. As a result, the Atlantic Flyway regulatory strategy is based exclusively on the status of American green-winged teal, wood ducks, ring-necked ducks, and goldeneyes breeding in the Atlantic Flyway states and eastern Canada. Since 2022, the Atlantic Flyway and the USFWS has implemented an independent AHM decision framework to inform harvest regulations for eastern mallards.

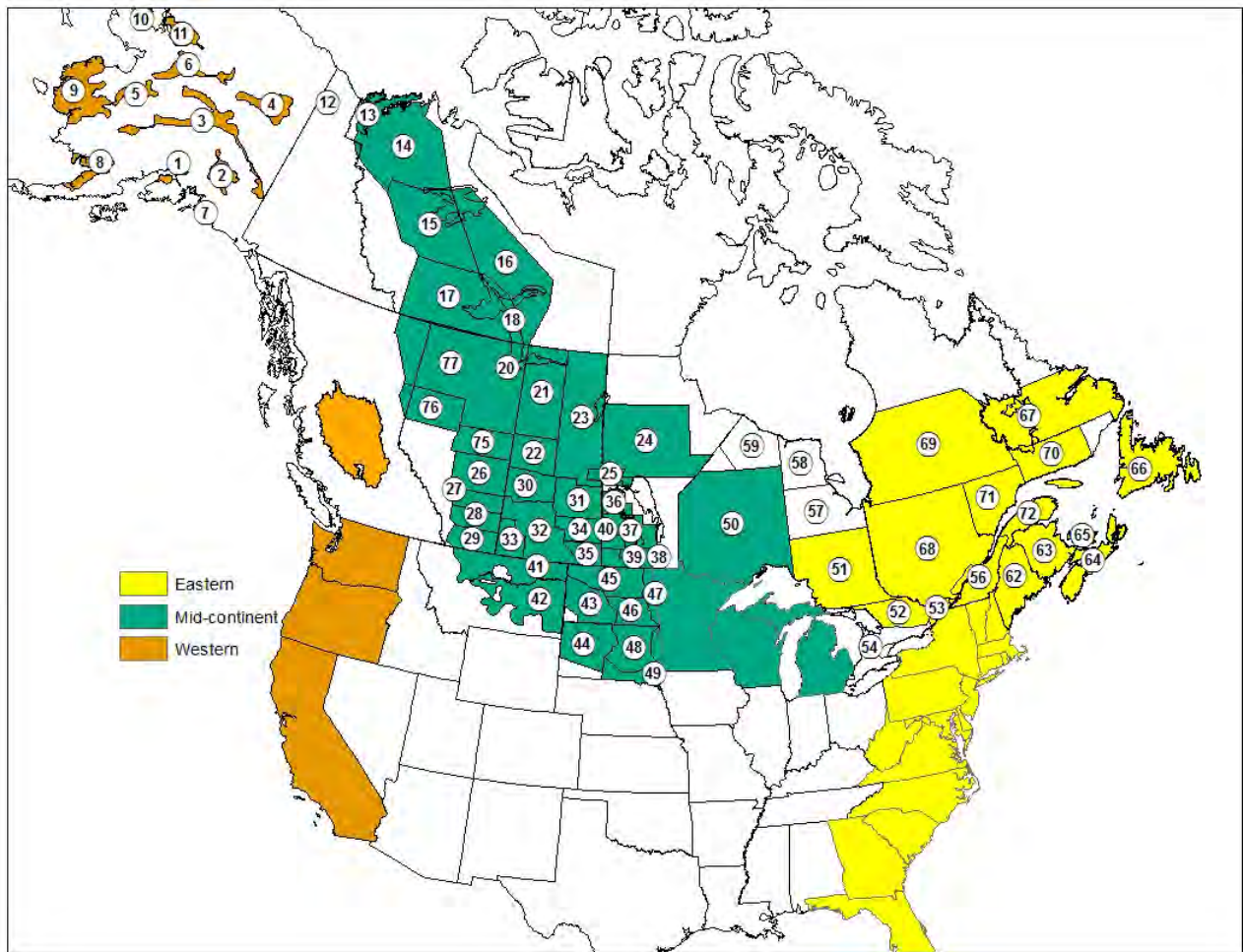

Figure 1 – Waterfowl Breeding Population and Habitat Survey (WBPHS) strata and state, provincial, and territorial survey areas currently assigned to the mid-continent and western stocks of mallards and eastern waterfowl stocks for the purposes of adaptive harvest management.

5 WATERFOWL POPULATION DYNAMICS

5.1 Mid-Continent Mallard Stock

Mid-continent mallards are defined as those breeding in WBPBS strata 13–18, 20–50, and 75–77, and in the Great Lakes region (Michigan, Minnesota, and Wisconsin; see [Figure 1](#)). Estimates of this population have varied from 6.2 to 11.9 million since 1992 ([Table D.1](#), [Figure 2](#)). Estimated breeding-population size in 2024 was 6.61 million (SE = 0.25 million), including 6.10 million (SE = 0.25 million) from the WBPBS and 0.51 million (SE = 0.05 million) from the Great Lakes region.

The key demographic relationships and estimation framework used to represent mid-continent mallards within an integrated population model is described in [Appendix D](#). We used Bayesian estimation methods in combination with a state-space model that accounts explicitly for both process and observation errors in breeding population sizes to estimate the uncertainty in the relationship between annual survival and harvest mortality along with the strength of density dependence in mid-continent mallard recruitment. The results from the integrated population model provide a reliable representation of mid-continent mallard population dynamics with realistic measures of uncertainty ([Figure 3](#)).

5.2 Western Mallard Stock

Western mallards consist of 2 substocks and are defined as those birds breeding in Alaska (WBPBS strata 1–12) and those birds breeding in the southern Pacific Flyway (California, Oregon, Washington, and British Columbia combined; see [Figure 1](#)). Estimates of these subpopulations have varied from 0.28 to 0.84 million in Alaska since 1990 and 0.43 to 0.64 million in the southern Pacific Flyway since 2010 ([Table E.1](#), [Figure 4](#)). In 2024, we estimated a breeding population size of 0.94 million (SE = 0.06 million), including 0.51 million (SE = 0.06 million) from Alaska and 0.43 million (SE = 0.03 million) from the southern Pacific Flyway.

Details concerning the set of population models for western mallards are provided in [Appendix E](#). To predict changes in abundance we used a discrete logistic model, which combines reproduction and natural mortality into a single parameter, r , the intrinsic rate of growth. This model assumes density-dependent growth, which is regulated by the ratio of population size, N , to the carrying capacity of the environment, K (i.e., equilibrium population size in the absence of harvest). In the traditional formulation of the logistic model, harvest mortality is completely additive and any compensation for hunting losses occurs as a result of density-dependent responses beginning in the subsequent breeding season. To increase the model's generality we included a scaling parameter for harvest that allows for the possibility of compensation prior to the breeding season. It is important to note, however, that this parameterization does not incorporate any hypothesized mechanism for harvest compensation and, therefore, must be interpreted cautiously. We modeled Alaska mallards independently of those in the southern Pacific Flyway because of differing population trajectories (see [Figure 4](#)) and substantial differences in the distribution of band recoveries.

We used Bayesian estimation methods in combination with a state-space model that accounts explicitly for both process and observation error in breeding population size ([Meyer and Millar 1999](#)). Breeding population estimates of mallards in Alaska are available since 1955, but we had to limit the time series to 1990–2019 and 2021–2024 because of changes in survey methodology and insufficient band-recovery data. The logistic model and associated posterior parameter estimates provided a reasonable fit to the observed time series of Alaska population estimates. The estimated median carrying capacity was 0.95 million and the median estimate of intrinsic rate of growth was 0.31. The posterior median estimate of the scaling parameter was 1.29. Breeding population and harvest-rate data were available for California-Oregon mallards for the period 1992–2024 except for 2020 and 2021. Because the British Columbia survey did not begin until 2006 and the Washington survey was redesigned in 2010, we imputed data in a Markov chain Monte Carlo (MCMC) framework from the beginning of the British Columbia and Washington surveys back to 1992 (see details in [Appendix E](#)) to make the time series consistent for the southern Pacific Flyway. The logistic model also provided a reasonable fit to these data. The estimated median carrying capacity was 0.85 million, and the median estimate of intrinsic rate of growth was 0.24. The posterior median estimate of the scaling parameter was 0.57.

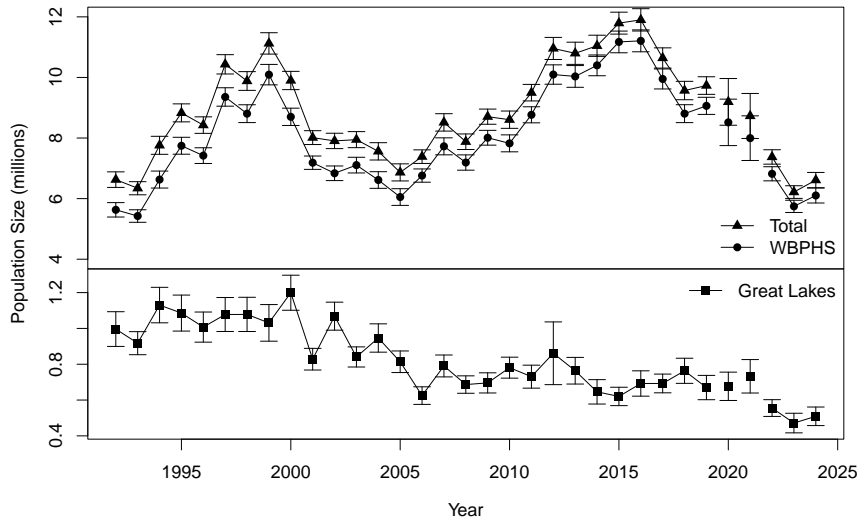

Figure 2 – Population estimates of mid-continent mallards observed in the WPBHS (strata: 13–18, 20–50, and 75–77) and the Great Lakes region (Michigan, Minnesota, and Wisconsin) from 1992–2024. Error bars represent one standard error. The 2020–21 values are based on model predictions.

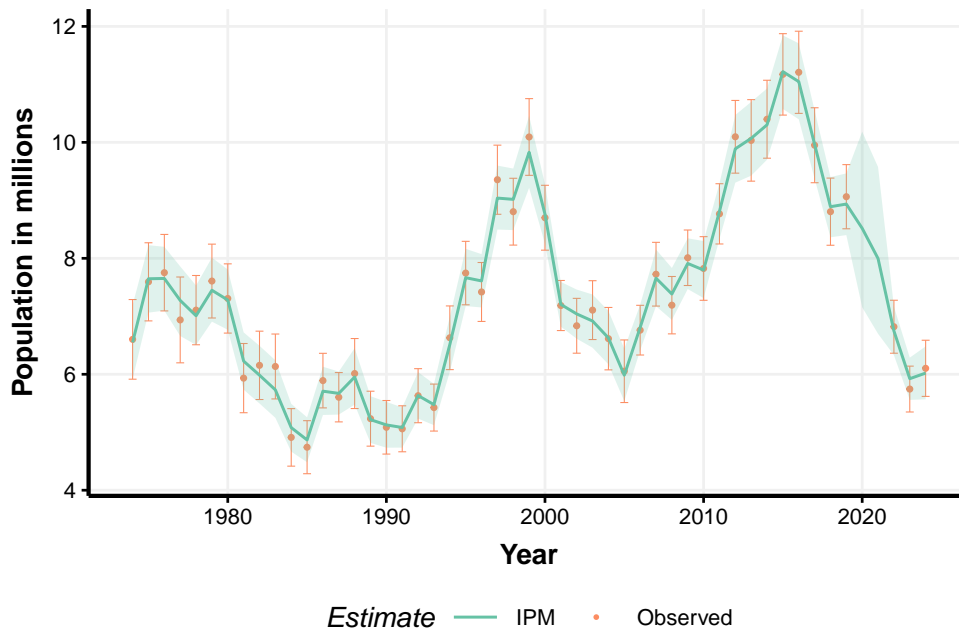

Figure 3 – Population estimates of mid-continent mallards observed from the WPBHS compared to mid-continent mallard integrated population model (IPM) predictions from 1974–2024. Error bars represent 95% confidence intervals while the error bands (line shading) represent 95% credibility intervals.

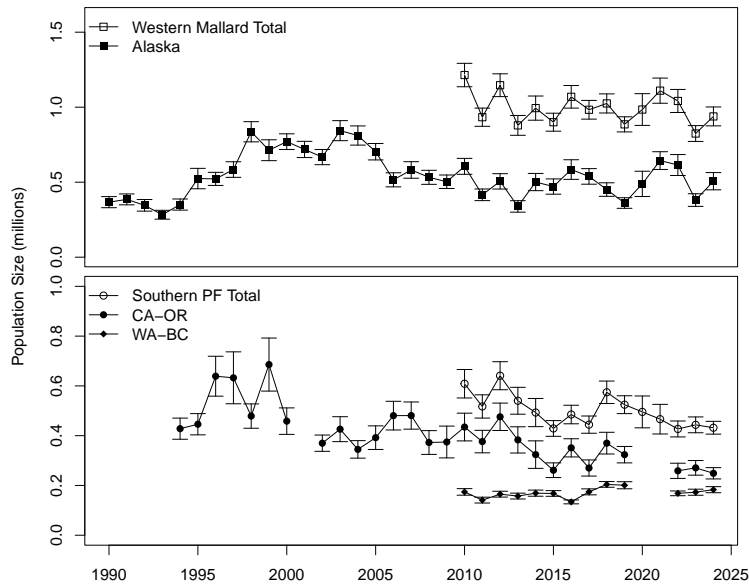

Figure 4 – Population estimates of western mallards observed in Alaska (WBPHS strata 1–12) and the southern Pacific Flyway (California, Oregon, Washington, and British Columbia combined) from 1990 to 2024. Error bars represent one standard error. The 2020 values for Alaska and the 2020–2021 values for the southern Pacific Flyway are based on model predictions.

The AHM protocol for western mallards is structured similarly to that used for mid-continent mallards, in which an optimal harvest strategy is based on the status of a single breeding stock (Alaska and southern Pacific Flyway substocks) and harvest regulations in a single Flyway. Although the contribution of mid-continent mallards to the Pacific Flyway harvest is significant, we believe an independent harvest strategy for western mallards poses little risk to the mid-continent stock. Further analyses will be needed to confirm this conclusion, and to better understand the potential effect of mid-continent mallard status on sustainable hunting opportunities in the Pacific Flyway.

5.3 Atlantic Flyway Multi-Stock

For the purposes of the Atlantic Flyway multi-stock AHM framework, eastern waterfowl stocks are defined as those breeding in eastern Canada and Maine (USFWS fixed-wing surveys in WBPHS strata 51–53, 56, and 62–70; CWS helicopter plot surveys in WBPHS strata 51–52, 63–64, 66–68, and 70–72) and Atlantic Flyway states from New Hampshire south to Virginia (AFBWS; Heusmann and Sauer 2000). These areas have been consistently surveyed since 1998. Breeding population size estimates for American green-winged teal, ring-necked ducks, and goldeneyes are derived annually by integrating USFWS and CWS survey data from eastern Canada and Maine (WBPHS strata 51–53, 56, and 62–72; Zimmerman et al. 2012, U.S. Fish and Wildlife Service 2019). Insufficient counts of American green-winged teal, ring-necked ducks, and goldeneyes in the AFBWS preclude the inclusion of those areas in the population estimates for those species. Breeding population size estimates for wood ducks in the Atlantic Flyway (Maine south to Florida) are estimated by integrating data from the AFBWS and the Breeding Bird Survey (BBS; Zimmerman et al. 2015). Insufficient counts of wood ducks from the USFWS and CWS surveys in Maine and Canada preclude incorporating those survey results into breeding population estimates. Estimates of the breeding population size for American green-winged teal have varied from 0.29 to 0.47 million, wood ducks varied from 0.87 to 0.95 million, ring-necked ducks varied from 0.61 to 0.95 million, and goldeneyes varied from 0.47 to 1.20 million since 1998 (Table F.1, Figure 5). Estimated breeding-population size in 2024 was 0.87 million (SE = 0.12 million) for wood ducks, 0.47 million (SE = 0.10 million) for American green-winged teal, 0.73 million (SE = 0.12 million) for ring-necked

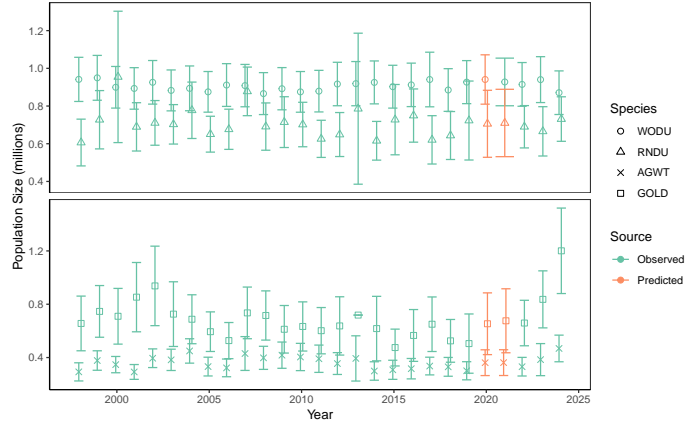

Figure 5 – Population estimates of American green-winged teal (AGWT), wood ducks (WODU), ring-necked ducks (RNDU), and goldeneyes (GOLD) observed in eastern Canada (WBPHS strata 51–53, 56, 62–72) and the U.S. (Atlantic Flyway states) from 1998 to 2024. Error bars represent one standard error. The SE of the goldeneyes estimate for 2013 is not reported due to insufficient counts. The 2020 values for each species are model predictions and 2021 values for each species except wood ducks are model predictions.

ducks, and 1.20 million (SE = 0.32 million) for goldeneyes.

Details concerning the set of models used in Atlantic Flyway multi-stock AHM are provided in [Appendix F](#). Similar to the methods used in western mallard AHM, we used a discrete logistic model to represent eastern waterfowl population and harvest dynamics and a state-space, Bayesian estimation framework to estimate the population parameters and process variation. We modeled each stock independently and found that the logistic model and associated posterior parameter estimates provided a reasonable fit to the observed time series of eastern waterfowl stocks. The estimated median carrying capacities were 0.50, 1.43, 0.87, and 0.80 for American green-winged teal, wood ducks, ring-necked ducks, and goldeneyes, respectively. The posterior median estimates of intrinsic rate of growth were 0.43, 0.36, 0.41, and 0.23 for American green-winged teal, wood ducks, ring-necked ducks, and goldeneyes, respectively.

6 HARVEST-MANAGEMENT OBJECTIVES

The basic harvest-management objective for mid-continent and western mallards is to maximize long-term cumulative (i.e., sustainable) harvest, which inherently requires perpetuation of a viable population. The harvest-management objective for eastern waterfowl stocks is to attain 98% of the maximum, long-term cumulative harvest for the aggregate of the four species.

At the request of the Flyway Councils, in 2003, the USFWS agreed to exclude closed duck-hunting seasons from the mid-continent mallard AHM protocol, when the population size of mid-continent mallards (as defined in 2003: WBPHS strata 1–18, 20–50, and 75–77 plus the Great Lakes region) was ≥ 5.5 million. Based on our original assessment, closed hunting seasons did not appear to be necessary from the perspective of sustainable harvesting when the mid-continent mallard population exceeded this level. The impact of maintaining open seasons above this level also appeared negligible for other mid-continent duck species, as based on population models developed by [Johnson \(2003\)](#).

In 2008, the mid-continent mallard stock was redefined to exclude mallards breeding in Alaska, necessitating a re-scaling of the closed-season constraint. Initially, we attempted to adjust the original 5.5 million closure threshold by subtracting out the 1985 Alaska breeding population estimate, which was the year upon which the original closed season constraint was based. Our initial re-scaling resulted in a new threshold equal to 5.25 million. Simulations based on optimal policies using this revised closed season constraint suggested that the Mississippi and Central Flyways would experience a 70% increase in the frequency of closed seasons. At that time, we agreed to consider

alternative re-scalings in order to minimize the effects on the mid-continent mallard strategy and account for the increase in mean breeding population sizes in Alaska over the past several decades. Based on this assessment, we recommended a revised closed season constraint of 4.75 million which resulted in a strategy performance equivalent to the performance expected prior to the re-definition of the mid-continent mallard stock. Because the performance of the revised strategy is essentially unchanged from the original strategy, we believe it will have no greater impact on other duck stocks in the Mississippi and Central Flyways. However, complete- or partial-season closures for particular species or populations could still be deemed necessary in some situations regardless of the status of mid-continent mallards.

7 REGULATORY ALTERNATIVES

7.1 *Evolution of Alternatives*

When AHM was first implemented in 1995, three regulatory alternatives characterized as liberal, moderate, and restrictive were defined based on regulations used during 1979–1984, 1985–1987, and 1988–1993, respectively. These regulatory alternatives also were considered for the 1996 hunting season. In 1997, the regulatory alternatives were modified to include: (1) the addition of a very-restrictive alternative; (2) additional days and a higher duck bag limit in the moderate and liberal alternatives; and (3) an increase in the bag limit of hen mallards in the moderate and liberal alternatives. In 2002, the USFWS further modified the moderate and liberal alternatives to include extensions of approximately one week in both the opening and closing framework dates. During the 2019–2020 regulatory process, closing dates for all four Flyways were set to 31 January for all regulatory alternatives to comply with the John D. Dingell, Jr. Conservation, Management, and Recreation Act.

In 2003, the very-restrictive alternative was eliminated at the request of the Flyway Councils. Expected harvest rates under the very-restrictive alternative did not differ significantly from those under the restrictive alternative, and the very-restrictive alternative was expected to be prescribed for <5% of all hunting seasons.

For the development of the multi-stock AHM framework in the Atlantic Flyway, the USFWS and Atlantic Flyway decided to keep the same overall bag limits and season lengths that were used for eastern mallard AHM. Species-specific regulations are then based on harvest strategies informed by existing decision frameworks (e.g., black duck AHM).

At the time this report was prepared, the regulatory packages for the 2025–26 seasons had not been finalized by the USFWS. However, we do not expect any changes from the 2024–25 packages. Therefore, optimal strategies were formulated using the 2024–25 packages and are referred to as “current” packages in subsequent text. Details of the regulatory alternatives for each Flyway are provided in [Table 1](#).

7.2 *Regulation-Specific Harvest Rates*

Harvest rates of mallards associated with each of the open-season regulatory alternatives were initially predicted using harvest-rate estimates from 1979–1984, which were adjusted to reflect current hunter numbers and contemporary specifications of season lengths and bag limits. In the case of closed seasons in the United States, we assumed rates of harvest would be similar to those observed in Canada during 1988–1993, which was a period of restrictive regulations both in Canada and the United States. All harvest-rate predictions were based only in part on band-recovery data, and relied heavily on models of hunting effort and success derived from hunter surveys (Appendix C in [U.S. Fish and Wildlife Service 2002](#)). As such, these predictions had large sampling variances and their accuracy was uncertain.

In 2002, we began using Bayesian statistical methods for improving regulation-specific predictions of harvest rates, including predictions of the effects of framework-date extensions. Essentially, the idea is to use existing (prior) information to develop initial harvest-rate predictions (as above), to make regulatory decisions based on those predictions, and then to observe realized harvest rates. Those observed harvest rates, in turn, are treated as new sources of information for calculating updated (posterior) predictions. Bayesian methods are attractive because they provide a quantitative, formal, and an intuitive approach to adaptive management.

Table 1 – Current regulatory alternatives for the duck-hunting season.

REGULATION	FLYWAY			
	Atlantic ^a	Mississippi	Central ^b	Pacific ^c
Shooting Hours	one-half hour before sunrise to sunset			
Opening Date				
Restrictive	October 1	Saturday nearest September 24		Saturday nearest October 1
Moderate	Saturday nearest September 24			
Liberal	Saturday nearest September 24			
Closing Date				
Restrictive	January 31			
Moderate	January 31			
Liberal	January 31			
Season Length (days)				
Restrictive	30	30	39	60
Moderate	45	45	60	86
Liberal	60	60	74	107
Bag Limit (total / mallard^d / hen mallard)				
Restrictive	3 / 1 / 1	3 / 2 / 1	3 / 3 / 1	4 / 3 / 1
Moderate	6 / 2 / 1	6 / 4 / 1	6 / 5 / 1	7 / 5 / 2
Liberal	6 / 4 / 2	6 / 4 / 2	6 / 5 / 2	7 / 7 / 2

^a The states of Maine, Massachusetts, Connecticut, Pennsylvania, New Jersey, Maryland, Delaware, and North Carolina are permitted to exclude Sundays, which are closed to hunting, from their total allotment of season days.

^b The High Plains Mallard Management Unit is allowed 12, 23, and 23 extra days in the restrictive, moderate, and liberal alternatives, respectively.

^c The Columbia Basin Mallard Management Unit is allowed 7 extra days in the restrictive and moderate alternatives.

^d For the Atlantic Flyway, the mallard bag limit is prescribed by the regulatory alternative under the Eastern Mallard AHM protocol.

Annual harvest rate estimates for mid-continent and western mallards and eastern stocks of American green-winged teal and wood ducks are updated with band-recovery information from a cooperative banding program between the USFWS and CWS, along with state, provincial, and other participating partners. Recovery rate estimates from these data are adjusted with reporting rate probabilities resulting from recent reward band studies (Boomer et al. 2013, Garrettson et al. 2013, Boomer et al. unpublished data, Garrettson et al. unpublished data). For mid-continent mallards, we have empirical estimates of harvest rate from the recent period of liberal hunting regulations (1998–2023). Bayesian methods allow us to combine these estimates with our prior predictions to provide updated estimates of harvest rates expected under the liberal regulatory alternative. Moreover, in the absence of experience (so far) with the restrictive and moderate regulatory alternatives, we reasoned that our initial predictions of harvest rates associated with those alternatives should be re-scaled based on a comparison of predicted and observed harvest rates under the liberal regulatory alternative. In other words, if observed harvest rates under the liberal alternative were 10% less than predicted, then we might also expect that the mean harvest rate under the moderate alternative would be 10% less than predicted. The appropriate scaling factors currently are based exclusively on prior beliefs about differences in mean harvest rate among regulatory alternatives, but they will be updated once we have experience with something other than the liberal alternative. A detailed description of the analytical framework for modeling mallard harvest rates is provided in [Appendix G](#).

In 2024, we used updated reporting rate probabilities for American green-winged teal and wood ducks using estimates from recent reward band studies on mid-continent mallards (Boomer et al. unpublished data) and American black ducks in the Atlantic Flyway and eastern Canada (Garrettson et al. unpublished data). Subsequently, we also updated

expected harvest rates under the closed, restrictive, and moderate alternatives using updated harvest rate estimates from 1998–2023 and expected reductions in harvest rates under each policy alternative. More detail on this update is provided in [Appendix G](#).

Our models of regulation-specific harvest rates also allow for the marginal effect of framework-date extensions in the moderate and liberal alternatives. A previous analysis by the [U.S. Fish and Wildlife Service \(2001\)](#) suggested that implementation of framework-date extensions might be expected to increase the harvest rate of mid-continent mallards by about 15%, or in absolute terms by about 0.02 (SD = 0.01). Based on the observed harvest rates during the 2002–2023 hunting seasons, the updated (posterior) estimate of the marginal change in harvest rate attributable to the framework-date extension is 0.004 (SD = 0.006). The estimated effect of the framework-date extension has been to increase harvest rate of mid-continent mallards by about 4% over what would otherwise be expected in the liberal alternative. However, the reader is strongly cautioned that reliable inference about the marginal effect of framework-date extensions ultimately depends on a rigorous experimental design (including controls and random application of treatments).

Current predictions of harvest rates of adult-male mid-continent mallards associated with each of the regulatory alternatives are provided in [Table 2](#). Predictions of harvest rates for the other age and sex cohorts are based on the mean ratios of cohort-specific harvest rates to adult-male rates ([Runge et al. 2002](#)). These ratios are updated each year within the mid-continent mallard IPM and are 1.94, 0.56, and 1.35 for young males, adult females, and young females, respectively. We make the simplifying assumption that the harvest rates of mid-continent mallards depend solely on the regulatory choice in the Mississippi and Central Flyways.

Based on available estimates of harvest rates of mallards banded in California and Oregon during 1990–1995 and 2002–2007, there was no apparent relationship between harvest rate and regulatory changes in the Pacific Flyway. This is unusual given our ability to document such a relationship in other mallard stocks and in other species. We note, however, that the period 2002–2007 was comprised of both stable and liberal regulations and harvest rate estimates were based solely on reward bands. In contrast, regulations were relatively restrictive during most of the earlier period and harvest rates were estimated based on standard bands using reporting rates estimated from reward banding during 1987–1988. Additionally, 1993–1995 were transition years in which full-address and toll-free bands were being introduced and information to assess their reporting rates (and their effects on reporting rates of standard bands) is limited. Thus, the two periods in which we wish to compare harvest rates are characterized not only by changes in regulations, but also in estimation methods.

Consequently, we lack a sound empirical basis for predicting harvest rates of western mallards associated with current regulatory alternatives other than liberal in the Pacific Flyway. In 2009, we began using Bayesian statistical methods for improving regulation-specific predictions of harvest rates (see [Appendix G](#)). The methodology is analogous to that currently in use for mid-continent mallards except that the marginal effect of framework date extensions in moderate and liberal alternatives is inestimable because there are no data prior to implementation of extensions. In 2008, we specified prior regulation-specific harvest rates of 0.01, 0.06, 0.09, and 0.11 with associated standard deviations of 0.003, 0.02, 0.03, and 0.03 for the closed, restrictive, moderate, and liberal alternatives, respectively. The prior for the liberal regulation was then updated in 2011 with a harvest rate of 0.12 and standard deviation of 0.04. The harvest rates for the liberal alternative were based on empirical estimates realized under the current liberal alternative during 2002–

Table 2 – Predictions of harvest rates of adult male, mid-continent and western mallards expected with application of the current regulatory alternatives in the Mississippi, Central, and Pacific Flyways.

Regulatory Alternative	Mid-Continent		Western	
	Mean	SD	Mean	SD
Closed (U.S.)	0.009	0.002	0.009	0.018
Restrictive	0.055	0.013	0.073	0.017
Moderate	0.094	0.021	0.122	0.029
Liberal	0.111	0.016	0.142	0.027

2007 and determined from adult male mallards banded with reward and standard bands adjusted for band reporting rates in the southern Pacific Flyway. The development of priors was based on banding information from California and Oregon data only. Recently, we assessed the band-recovery data from Washington, Idaho, and British Columbia and found that the addition of these bands had a negligible influence on harvest rate estimates of western mallards. As a result, we have included Washington, Idaho, and British Columbia band-recovery information in our annual updates to western mallard harvest rate distributions. Harvest rates for the moderate and restrictive alternatives were based on the proportional (0.85 and 0.51) difference in harvest rates expected for mid-continent mallards under the respective alternatives. Finally, harvest rate for the closed alternative was based on what we might realize with a closed season in the United States (including Alaska) and a very restrictive season in Canada, similar to that for mid-continent mallards. A relatively large standard deviation (CV = 0.3) was chosen to reflect greater uncertainty about the means than that for mid-continent mallards (CV = 0.2). Current predictions of harvest rates of adult male western mallards associated with each regulatory alternative are provided in [Table 2](#).

The harvest rates expected under the liberal season for the four populations associated with the Atlantic Flyway’s multi-stock AHM were based on the average observed harvest rates from 1998–2023 for each species. The harvest rates for American green-winged teal and wood ducks were based on preseason banding and dead recovery data adjusted for reporting rates similar to mid-continent and western mallards. Because the discrete logistic model used for these species does not include age or sex structure, banding data for all cohorts were pooled to estimate an overall harvest rate. Insufficient banding data precluded the estimation of harvest rates for ring-necked ducks and goldeneyes in the Atlantic Flyway based on band recovery information, so harvest estimates from the Harvest Information Program were used to monitor harvest levels for these species in the multi-stock framework. Specifically, we estimated a fall population size from the discrete logistic model and calculated a harvest rate as the total harvest divided by the fall population size for ring-necked ducks and goldeneyes. The estimated harvest rates for each species under each regulation are listed in [Table 3](#).

Table 3 – Predictions of harvest rates of American green-winged teal (AGWT), wood ducks (WODU), ring-necked ducks (RNDU), and goldeneyes (GOLD) expected under closed, restrictive, moderate, and liberal regulations in the Atlantic Flyway.

Regulatory Alternative	AGWT	WODU	RNDU	GOLD
Closed (U.S.)	0.007	0.003	0.011	0.001
Restrictive	0.053	0.070	0.056	0.007
Moderate	0.082	0.086	0.093	0.013
Liberal	0.108	0.116	0.126	0.026

8 OPTIMAL REGULATORY STRATEGIES

The adoption of the preferred alternative specified in SEIS 2013 ([U.S. Department of the Interior 2013](#)) resulted in a new decision process based on a single regulatory meeting in the fall of year t to inform regulations for the next year’s hunting season in year $t + 1$ ([Appendix A](#)). As a result, regulatory decisions are made in advance of observing the status of waterfowl breeding populations (BPOP) and habitat conditions during the spring prior to the upcoming hunting season. With the implementation of the SEIS, pre-survey regulatory decisions introduce a lag in the AHM process where model updating and state-dependent decision making are now governed by the previous year’s monitoring information. Given that the original AHM protocols and decision frameworks were structured to inform decisions based on current monitoring information (i.e., post-survey), several technical adjustments and a new optimization framework were developed to support a pre-survey decision process. We revised the optimization procedures used to derive harvest policies by structuring the decision process based on the information that is available at the time of the decision, which includes the previous year’s observation of the system, the previous year’s regulation, and the latest update of model weights. Based on this new formulation, the prediction of future system states and harvest values now account for all possible outcomes from previous decisions, and as a result, the optimal policy is now conditional on the previous year’s regulation. We modified the optimization code used for each AHM decision framework in order to continue to use stochastic dynamic programming ([Williams et al. 2002](#)) to derive optimal harvest

policies while accounting for the pre-survey decision process (Johnson et al. 2016). Adjustments to these optimization procedures necessitated considerations of how closed season constraints and different objective functions were represented. Currently, we have implemented the closed season constraints conditional on the last observed state. With the cooperation of the Harvest Management Working Group, we are exploring alternative ways to implement these constraints that would be more consistent with the intent of the original specification (i.e., post-survey decision framework). A comparison of optimization and simulation results from pre- and post-survey AHM protocols suggested that the adjustments to the optimization procedures to account for changes in decision timing were not expected to result in major changes in expected management performance (Boomer et al. 2015). Updated optimization code was developed with the MDPSOLVE© (Fackler 2011) software tools implemented in MATLAB (2016).

Using stochastic dynamic programming (Williams et al. 2002) to evaluate a pre-survey decision process, we calculated the optimal regulatory strategy for the Mississippi and Central Flyways based on: (1) the objective of maximizing long-term cumulative harvest; (2) current regulatory alternatives and the closed-season constraint; and (3) current mid-continent mallard population models and parameter estimates. The resulting regulatory strategy includes options conditional on the regulatory alternative selected the previous hunting season (Figure 6). Note that prescriptions for closed seasons in this strategy represent resource conditions that are insufficient to support one of the current regulatory alternatives, given current harvest-management objectives and constraints. However, closed seasons under all of these conditions are not necessarily required for long-term resource protection, and simply reflect current management objectives and the nature of the current regulatory alternatives. Assuming that harvest management adhered to this strategy (and that current models accurately reflect population dynamics), breeding-population size would be expected to average 7.79 million (SE = 0.034 million). Based on a liberal regulatory alternative selected for the 2024 hunting season, an observed breeding population size of 6.61 million mid-continent mallards and 5.16 million total ponds observed in Prairie Canada and the U.S., the optimal choice for the 2025 hunting season in the Mississippi and Central Flyways is the liberal regulatory alternative (Table 4).

We calculated the optimal regulatory strategy for the Pacific Flyway based on: (1) an objective to maximize long-term cumulative harvest; (2) current regulatory alternatives; and (3) current population models and parameter estimates. The resulting regulatory strategy includes options conditional on the regulatory alternative selected the previous hunting season (Figure 7). We simulated the use of this regulatory strategy to determine expected performance characteristics. Assuming that harvest management adhered to this strategy (and that current model parameters accurately reflect population dynamics), breeding-population size would be expected to average 0.55 million (SD = 0.06 million) in Alaska and 0.52 million (SD = 0.05 million) in the southern Pacific Flyway. Based on a liberal regulatory alternative selected for the 2024 hunting season, an observed 2024 breeding population size of 0.51 million mallards for Alaska and 0.43 million for the southern Pacific Flyway, the optimal choice for the 2025 hunting season in the Pacific Flyway is the liberal regulatory alternative (Table 5).

We calculated the optimal regulatory strategy for the Atlantic Flyway based on: (1) an objective to achieve 98% of the maximum, long-term cumulative harvest for the aggregate of the four species; (2) current regulatory alternatives; and (3) current population models and parameter estimates. The resulting regulatory strategy includes options conditional on the regulatory alternative selected the previous hunting season (Figure 8). We simulated the use of this regulatory strategy to determine expected performance characteristics. Assuming that harvest management adhered to this strategy (and that the population models accurately reflect population dynamics), breeding-population sizes would be expected to average 0.37 (SD = 0.03), 0.93 (SD = 0.05), 0.57 (SD = 0.04), and 0.71 (SD = 0.11) million for American green-winged teal, wood ducks, ring-necked ducks, and goldeneyes, respectively. Based on a liberal regulatory alternative selected for the 2024 hunting season, estimated 2024 breeding population sizes of 0.47 million American green-winged teal, 0.87 million wood ducks, 0.73 million ring-necked ducks, and 1.20 million goldeneyes, the optimal choice for 2025 hunting season in the Atlantic Flyway is the liberal regulatory alternative (see Table 6).

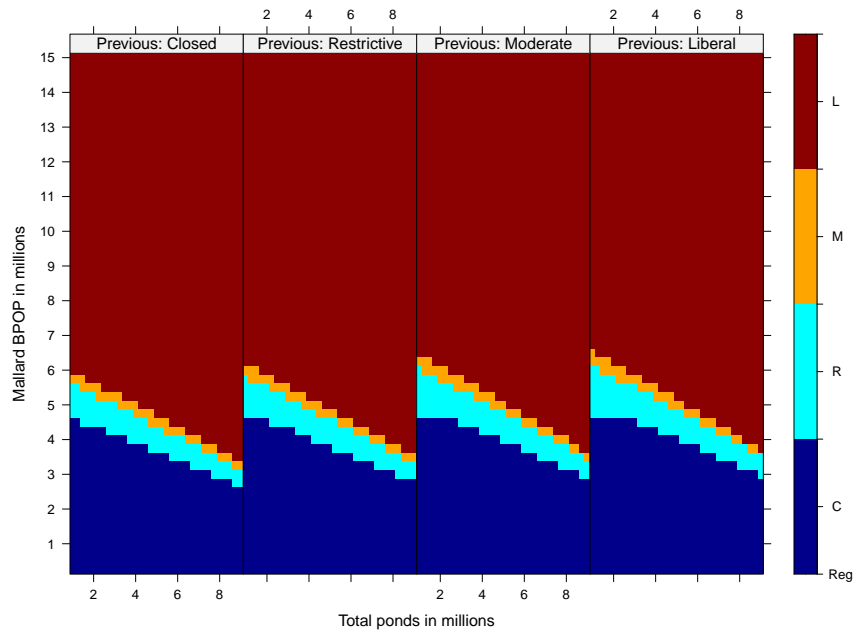

Figure 6 – Mid-continent mallard pre-survey harvest policies derived with current regulatory alternatives (including the closed-season constraint), updated mid-continent mallard model parameter estimates, and an objective of maximizing long-term cumulative harvest.

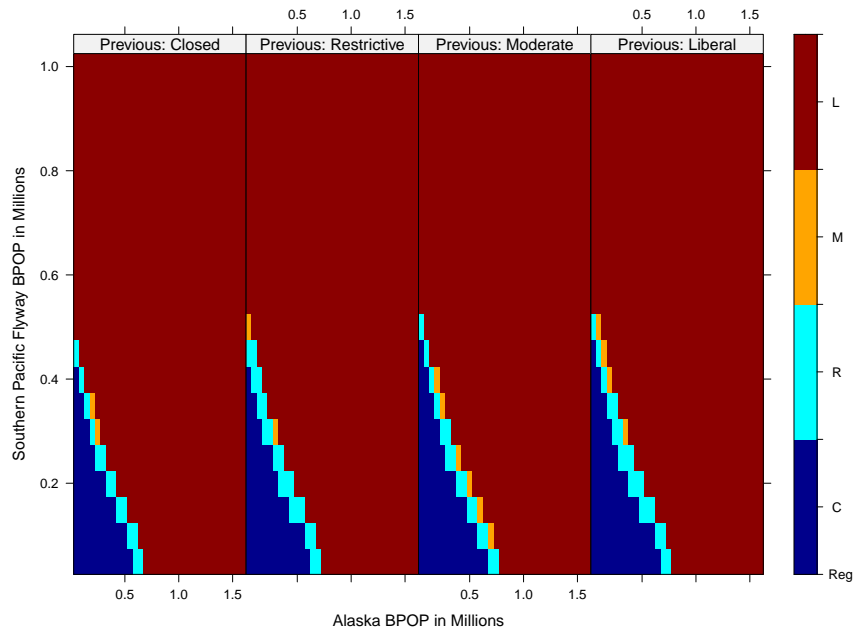

Figure 7 – Western mallard pre-survey harvest policies derived with current regulatory alternatives, updated (1990–2024) western mallard population models and parameter estimates, and an objective to maximize long-term cumulative harvest.

Table 4 – Optimal regulatory strategy^a for the Mississippi and Central Flyways for the 2025 hunting season predicated on a liberal alternative selected the previous year (2024). This strategy is based on the current regulatory alternatives (including the closed-season constraint), updated mid-continent mallard model parameters, and an objective of maximizing long-term cumulative harvest. The shaded cell indicates the regulatory prescription for the 2025 hunting season.

BPOP ^b	Ponds ^c																				
	3	3.25	3.5	3.75	4	4.25	4.5	4.75	5	5.25	5.5	5.75	6	6.25	6.5	6.75	7	7.25	7.5	7.75	8
≤3	C	C	C	C	C	C	C	C	C	C	C	C	C	C	C	C	C	C	C	C	C
3.25	C	C	C	C	C	C	C	C	C	C	C	C	C	C	C	C	C	C	C	C	R
3.5	C	C	C	C	C	C	C	C	C	C	C	C	C	C	C	C	R	R	R	R	R
3.75	C	C	C	C	C	C	C	C	C	C	C	C	C	R	R	R	R	R	R	R	R
4	C	C	C	C	C	C	C	C	C	R	R	R	R	R	R	R	R	R	R	M	M
4.25	C	C	C	C	C	R	R	R	R	R	R	R	R	R	R	R	M	M	M	L	L
4.5	C	R	R	R	R	R	R	R	R	R	R	R	R	M	M	M	L	L	L	L	L
4.75	R	R	R	R	R	R	R	R	R	R	M	M	M	L	L	L	L	L	L	L	L
5	R	R	R	R	R	R	R	M	M	M	L	L	L	L	L	L	L	L	L	L	L
5.25	R	R	R	R	M	M	M	M	L	L	L	L	L	L	L	L	L	L	L	L	L
5.5	R	M	M	M	M	L	L	L	L	L	L	L	L	L	L	L	L	L	L	L	L
5.75	M	M	L	L	L	L	L	L	L	L	L	L	L	L	L	L	L	L	L	L	L
6	L	L	L	L	L	L	L	L	L	L	L	L	L	L	L	L	L	L	L	L	L
6.25	L	L	L	L	L	L	L	L	L	L	L	L	L	L	L	L	L	L	L	L	L
6.5	L	L	L	L	L	L	L	L	L	L	L	L	L	L	L	L	L	L	L	L	L
6.75	L	L	L	L	L	L	L	L	L	L	L	L	L	L	L	L	L	L	L	L	L
7	L	L	L	L	L	L	L	L	L	L	L	L	L	L	L	L	L	L	L	L	L
7.25	L	L	L	L	L	L	L	L	L	L	L	L	L	L	L	L	L	L	L	L	L
7.5	L	L	L	L	L	L	L	L	L	L	L	L	L	L	L	L	L	L	L	L	L
7.75	L	L	L	L	L	L	L	L	L	L	L	L	L	L	L	L	L	L	L	L	L
8	L	L	L	L	L	L	L	L	L	L	L	L	L	L	L	L	L	L	L	L	L
8.25	L	L	L	L	L	L	L	L	L	L	L	L	L	L	L	L	L	L	L	L	L
8.5	L	L	L	L	L	L	L	L	L	L	L	L	L	L	L	L	L	L	L	L	L
8.75	L	L	L	L	L	L	L	L	L	L	L	L	L	L	L	L	L	L	L	L	L
9	L	L	L	L	L	L	L	L	L	L	L	L	L	L	L	L	L	L	L	L	L
≥9.25	L	L	L	L	L	L	L	L	L	L	L	L	L	L	L	L	L	L	L	L	L

^a C = closed season, R = restrictive, M = moderate, L = liberal.

^b Mallard breeding population size (in millions) observed in the WBPBS (strata 13–18, 20–50, 75–77) and Michigan, Minnesota, and Wisconsin.

^c Total ponds (in millions) observed in the United States and Canada in the WBPBS (strata 26–49).

Table 5 – Optimal regulatory strategy^a for the Pacific Flyway for the 2025 hunting season predicated on a liberal alternative selected the previous year (2024). This strategy is based on current regulatory alternatives, updated (1990–2024) western mallard population models and parameter estimates, and an objective to maximize long-term cumulative harvest. The shaded cell indicates the regulatory prescription for 2025.

Southern Pacific Flyway BPOP ^c	Alaska BPOP ^b														
	0.05	0.10	0.15	0.20	0.25	0.30	0.35	0.40	0.45	0.50	0.55	0.60	0.65	0.70	≥0.75
0.05	C	C	C	C	C	C	C	C	C	C	C	C	C	R	R
0.10	C	C	C	C	C	C	C	C	C	C	C	C	R	R	L
0.15	C	C	C	C	C	C	C	C	C	R	R	R	L	L	L
0.20	C	C	C	C	C	C	C	R	R	R	L	L	L	L	L
0.25	C	C	C	C	C	R	R	R	L	L	L	L	L	L	L
0.30	C	C	C	C	R	R	M	L	L	L	L	L	L	L	L
0.35	C	C	C	R	R	L	L	L	L	L	L	L	L	L	L
0.40	C	C	R	M	L	L	L	L	L	L	L	L	L	L	L
0.45	C	R	M	L	L	L	L	L	L	L	L	L	L	L	L
0.50	R	M	L	L	L	L	L	L	L	L	L	L	L	L	L
0.55	L	L	L	L	L	L	L	L	L	L	L	L	L	L	L
0.60	L	L	L	L	L	L	L	L	L	L	L	L	L	L	L
0.65	L	L	L	L	L	L	L	L	L	L	L	L	L	L	L
0.70	L	L	L	L	L	L	L	L	L	L	L	L	L	L	L
≥0.75	L	L	L	L	L	L	L	L	L	L	L	L	L	L	L

^a C = closed season, R = restrictive, M = moderate, L = liberal.

^b Estimated number of mallards (in millions) observed in Alaska (WBPHS strata 1–12).

^c Estimated number of mallards (in millions) observed in the southern Pacific Flyway (California, Oregon, Washington, and British Columbia combined).

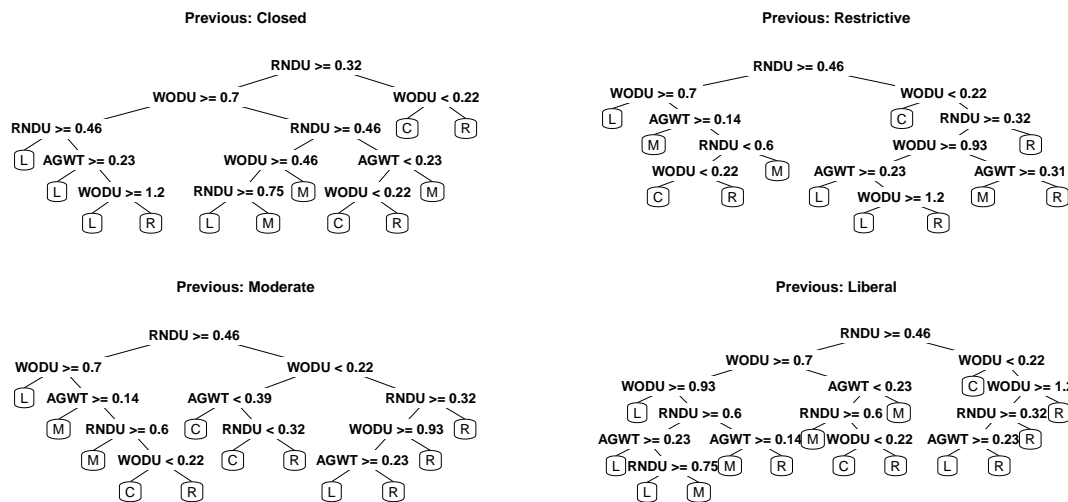

Figure 8 – A graphical representation of the Atlantic Flyway multi-stock pre-survey harvest policies derived with current regulatory alternatives, updated (1998–2024) population models and parameter estimates, and an objective to achieve 98% of the maximum, long-term cumulative harvest of the aggregate stocks. The classification trees are a statistical representation of the policies and do not depict all possible combinations of breeding population states and regulatory alternatives.

Table 6 – Optimal regulatory strategy^a for the Atlantic Flyway for the 2025 hunting season. This strategy is based on current regulatory alternatives, species-specific population models and parameter estimates, and an objective to achieve 98% of the maximum, long-term cumulative harvest of the aggregate stocks. Predicated on a liberal alternative selected the previous year (2024), the shaded cells indicate current breeding population sizes and the regulatory prescription for 2025.

Species ^b Population (in millions)				
AGWT	WODU	RNDU	GOLD	Regulation
0.352	0.814	0.676	0.968	L
0.352	0.814	0.676	1.185	L
0.352	0.814	0.82	0.968	L
0.352	0.814	0.82	1.185	L
0.352	1.052	0.676	0.968	L
0.352	1.052	0.676	1.185	L
0.352	1.052	0.82	0.968	L
0.352	1.052	0.82	1.185	L
0.436	0.814	0.676	0.968	L
0.436	0.814	0.676	1.185	L
0.436	0.814	0.82	0.968	L
0.436	0.814	0.82	1.185	L
0.436	1.052	0.676	0.968	L
0.436	1.052	0.676	1.185	L
0.436	1.052	0.82	0.968	L
0.436	1.052	0.82	1.185	L

^a C = closed season, M = moderate, R = restrictive, L = liberal.

^b AGWT = American green-winged teal, WODU = wood duck, RNDU = ring-necked duck, GOLD = goldeneyes.

9 APPLICATION OF ADAPTIVE HARVEST MANAGEMENT TO OTHER STOCKS

The USFWS and their partners have successfully applied the principles and tools of AHM to improve decision-making for several other stocks of waterfowl. Below, we provide AHM updates for the 2025 hunting season that are currently informing American black duck, northern pintail, scaup, and eastern mallard harvest management decisions.

9.1 American Black Duck

Federal, state, and provincial agencies in the U.S. and Canada agreed that an international harvest strategy for black ducks is needed because the resource is valued by both countries and both countries have the ability to influence the resource through harvest. The partners also agreed a harvest strategy should be developed with an AHM approach based on the integrated breeding-ground survey data (Zimmerman et al. 2012, U.S. Fish and Wildlife Service 2019). Finally, the strategy should also provide a formal approach to determining appropriate harvest levels and fair allocation of the harvest between countries (Conroy 2010).

The overall goals of the Black Duck International Harvest strategy include:

- (1) maintain a black duck population that meets legal mandates and provides consumptive and non-consumptive use commensurate with habitat carrying capacity;
- (2) maintain societal values associated with the hunting tradition; and
- (3) maintain equitable access to the black duck resource in Canada and the U.S.

The objectives of the harvest strategy are to achieve 98% of the long-term cumulative harvest and to share the allocated harvest equitably between countries (i.e., parity). Historically, the realized allocation of harvest between Canada and the U.S. has ranged from 40% to 60% in either country. Recognizing the historical allocation and acknowledging incomplete control over harvest, parity is achieved through a constraint which discounts combinations of country-specific harvest rates that are expected to result in allocation of harvest that is >50% in one country. The constraint applies a mild penalty on country-specific harvest options that result in one country receiving >50% but <60% of the harvest allocation and a stronger discount on combinations resulting in one country receiving >60% of the harvest allocation (Figure 9). The goals and objectives of the black duck AHM framework were developed through a formal consultation process with representatives from the CWS, USFWS, Atlantic Flyway Council and Mississippi Flyway Council.

Country-specific harvest opportunities were determined from a set of expected harvest rate distributions defined as regulatory alternatives. Canada has developed 4 regulatory alternatives (liberal, moderate, restrictive and closed); and the U.S. has developed 3 (moderate, restrictive, closed). We fit a generalized linear model to direct recoveries of black ducks banded in eastern Canada (Ontario, Quebec, New Brunswick, Nova Scotia, Prince Edward Island, Newfoundland, and Labrador) from 1990–2023 to predict harvest rate distributions. Annual harvest rates were derived by adjusting band recoveries by country- and band inscription-specific reporting rates, and reporting rates were treated as known. In both Canada and the U.S., reporting rate estimates for bands inscribed with 1-800 numbers or web addresses have changed over time (2002–2004: [Garrettson et al. 2013](#), 2017–2019: Garrettson unpubl. report). We imputed reporting rates for 1-800 bands and web-address bands for interim years using a simple linear trend (Figure 10).

Harvest rates were modeled in a Bayesian context. Harvest in a given year (indexed by t) of an age-sex class (indexed by j) in either country (indexed by z) was assumed to be a random Binomial process $H_{t,j,z} \sim \text{Binomial}(R_{t,j,z}, h_{t,j,z})$, where R represents the total number of banded birds released in eastern Canada and available to be harvested, H is the number of banded and released birds that were harvested, and h represents an expected harvest rate. For any given

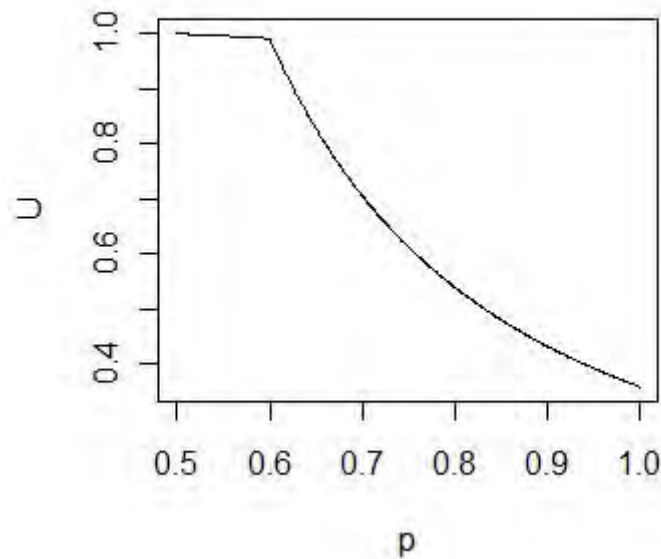

Figure 9 – Functional form of the harvest parity constraint designed to allocate allowable black duck harvest equally between the U.S. and Canada. The value of p is the proportion of harvest allocated to one country, and U is the utility of a specific combination of country-specific harvest options in achieving the objective of black duck adaptive harvest management.

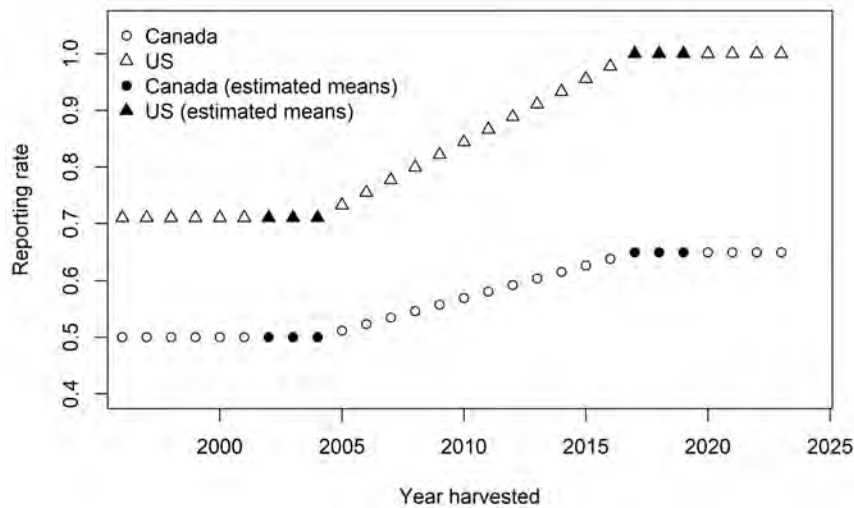

Figure 10 – Updated reporting rates for bands with 1-800 number and web address inscriptions used to estimate black duck harvest rates. Filled symbols are estimates from reward band studies and empty symbols are values imputed based on a linear trend.

year the expected harvest rate for each age-sex class in each country was assumed to come from a baseline harvest rate, the effect of the country-specific harvest policy, and a time trend. There was strong evidence of a negative trend in adult male harvest over time in Canada (median = -0.035 , -0.045 – -0.025 95% CI; 1.00 probability of decline) and in the U.S. (median = -0.015 , -0.024 – -0.006 95% CI; 1.00 probability of decline). There was a strong effect of liberalizing policies on adult male harvest rates in Canada (median = 0.458 , 0.174 – 0.741 95% CI; 1.00 probability of positive effect). There was also a positive but less clear effect of liberalizing policies on adult male harvest in the U.S. (median = 0.073 , -0.192 – 0.337 95% CI; 0.70 probability of positive effect).

We used the posterior distributions of model parameters to predict adult male harvest rates for the 2025–26 season under moderate and liberal alternatives in Canada and restrictive and moderate alternatives in the U.S. (Figure 11). Since the implementation of black duck AHM, neither the closed alternative (in either country) or the restrictive alternative in Canada have been implemented. Therefore, we assume a distribution with mean harvest rate of 0.01 (± 0.001 SE) for the closed alternative, and for the Canadian restrictive alternative we assume a 30% decrease from predicted harvest under the moderate alternative. The closed alternative requires either country to prohibit black duck harvest. Canada and the U.S. will determine, independently, appropriate regulations designed to achieve their prescribed harvest rate targets as identified under the regulatory alternatives. Regulations will vary independently between countries based on the status of the population and optimal strategy as determined through the AHM protocol.

Initial assessment of black duck AHM in 2022 indicated that differences in predicted harvest rates between countries would trigger strong penalties under the parity constraint, resulting in a restriction of U.S. harvest even when Canada was under a liberal regulatory option. This type of penalty did not align with the original intent of the parity constraint; therefore, for the 2023-24, 2024-25, and 2025-26 policy optimizations the parity constraint was temporarily modified so that if one country was under its most liberal regulatory alternative (i.e., liberal in Canada or moderate in the U.S.), the other country could not be penalized by the constraint. The CWS, USFWS, Atlantic and Mississippi Flyways have initiated negotiations to reconsider and define the parity constraints to achieve mutually agreed upon goals under current conditions.

The AHM integrated population model is based on spring breeding-ground abundance as estimated by the integrated Eastern Waterfowl Survey. Prior to 2023, we only incorporated estimates from the core survey area (WBPHS strata 51, 52, 63, 64, 66, 67, 68, 70, 71, and 72), however, starting with the 2023 assessment we updated the spatial scale

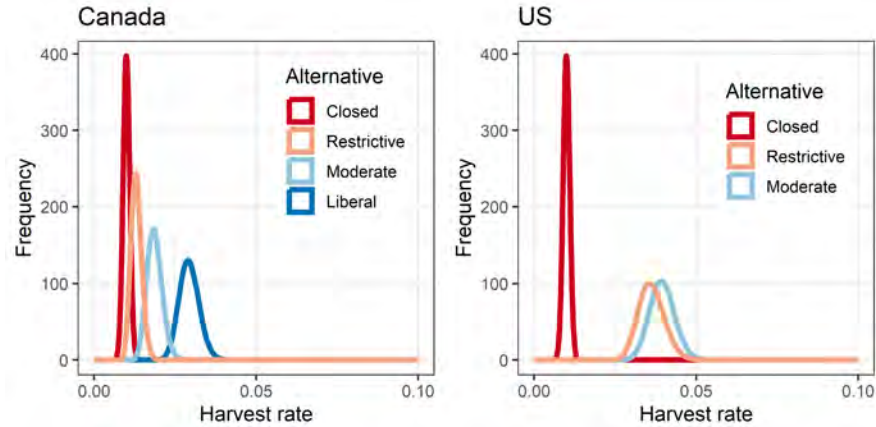

Figure 11 – Predictive harvest rate distributions for adult male black ducks expected under the application of the current regulatory alternatives in Canada (left) and the U.S. (right).

of abundance estimates to eastern Canada (WBPHS strata 51–53, 56, 62–72). The American black duck population measure is based on “indicated pairs.” Prior to 2023, indicated pairs were defined as 1 individual observed equals 1 indicated pair whereas a group of 2 is assumed to represent 1.5 indicated pairs. This definition was based on sex-specific observations from previous CWS surveys that indicated approximately 50% of observed groups of 2 were male-male. However, updated observation data from Quebec and New Jersey from 1990–2009 indicated that the majority of observed pairs were male-female. In 2023, we updated the indicated pairs definition to define groups of 2 as 1 indicated pair. Black duck total indicated birds were calculated using standard USFWS protocols.

Fall age ratios are estimated using harvest age ratios derived from the USFWS and CWS parts collection surveys, adjusted for differential vulnerability. Age- and sex-specific harvest rates are based on direct recoveries of black ducks banded in Canada from 1990–2023 adjusted by country- and band inscription-specific reporting rates. Direct and indirect band recoveries of adult and juvenile male and female black ducks banded in Canada from 1990–2023 were used to estimate age- and sex-specific annual survival rates.

The black duck AHM framework has been based on two hypotheses regarding black duck population ecology. The first hypothesis stated that black duck population growth was limited by competition with mallards during the breeding season. As the effect of mallard competition ($c2$) increases, black duck productivity decreases which then limits black duck population growth. The second hypothesis stated that black duck population growth was limited by harvest because hunting mortality is additive to natural mortality. As the effect of harvest mortality, or additivity ($a1$) increases, annual survival decreases and limits black duck population growth. The AHM framework incorporated each of these hypotheses into a single parametric (i.e., regression) model.

In 2023, because of concerns with the form of the mallard population model informing the competition parameter (i.e., fixed annual estimates with added random variation), we investigated the predictive ability of several candidate productivity sub-models using leave-future-out cross validation. Candidate models included two general classes: models with fixed intercepts and a negative time trend and models with an intercept drawn annually from a global distribution with no time trend. Models with random annual intercepts performed better than fixed intercept models. And, we found no appreciable difference in the predictive capacity of these models with and without the mallard competition parameter. The black duck integrated population model and optimization protocol was therefore updated to remove mallards as a state variable. These revisions to the productivity sub-model as well as other technical revisions mentioned above were developed in consultation with representatives from the CWS, USFWS, Atlantic Flyway Council and Mississippi Flyway Council.

Estimates of the additivity parameter are updated with current year’s monitoring data (Figure 12) and are used to establish annual harvest regulations. In 2022 we updated reporting rates which impacted $a1$ and in 2023 we updated the integrated population model. To accurately depict any change in additivity over time, historical estimates of $a1$ were updated by retroactively analyzing years prior to 2023 with the updated model and reporting rates (see Figure 12).

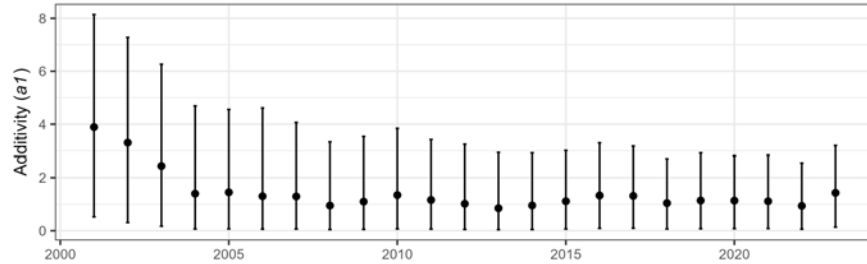

Figure 12 – Median estimates of the black duck harvest additivity ($a1$) parameter over time. Error bars represent 95% credibility intervals.

Optimal country-specific regulatory strategies for the 2025–26 hunting season were calculated using: (1) the black duck harvest objective (98% of long-term cumulative harvest); (2) current, country-specific regulatory alternatives (see Figure 11); (3) the current parameter estimate for additive mortality (see Figure 12); (4) 2024 estimates of 0.86 million breeding black ducks in eastern Canada; and (5) the country-specific 2024–25 regulations (liberal in Canada and moderate in the U.S). The optimal regulatory choices are the liberal alternative in Canada and moderate alternative in the U.S. (Table 7).

9.2 Northern Pintails

In 2010, the Flyway Councils and the USFWS established an adaptive management framework to inform northern pintail harvest decisions. After several years of experience, the Flyway councils expressed an interest in revisiting several key policy and technical issues associated with pintail AHM, including updating pintail data sources and the pintail population models, while also reconsidering the inclusion of a 3-bird daily bag limit. A Pintail Working Group (PWG) was established to oversee this effort and evaluate a number of alternative harvest strategies. As a result, all of the pintail monitoring datasets have been updated and analyzed with a newly developed Integrated Population Model (IPM) within a Bayesian estimation framework (Appendix H). After extensive consultation with each Flyway, the PWG recommended the adoption of an interim adaptive harvest management strategy to inform pintail harvest regulations starting with the 2025–26 hunting season. The new pintail harvest strategy would be implemented on an experimental basis until three seasons of a 3-bird bag limit have been realized while allowing for two years to analyze data and conduct a full evaluation of the interim strategy. Based on the results of a formal review of this evaluation, the adoption of an operational Northern Pintail Harvest Strategy will be considered and negotiated by the Flyways and the USFWS.

The fundamental objectives for the interim northern pintail harvest strategy include conserving the pintail population in perpetuity, providing hunting opportunity commensurate with population status, minimizing regulatory burden to the public, communicating effectively with stakeholders and the public, encouraging hunting participation, maintaining parity of hunting across Flyways, and providing for other non-consumptive uses. The interim harvest strategy attempts to balance these multiple objectives by 1) maximizing the long-term cumulative harvest, which inherently requires perpetuation of a viable population, 2) providing an open season when the observed breeding population is above 1.2 million birds, 3) allowing a liberal season with a 3-bird daily bag limit under some conditions, and 4) providing a fixed 3-bird bag-limit in the Atlantic Flyway when the season is open in the other Flyways. These harvest management objectives were translated into an objective function that is specified under a constraint that provides for an open hunting season when the observed breeding population is ≥ 1.2 million birds. The final objective function and the use of the population constraint, in conjunction with the regulatory alternatives, were determined after an intensive consultation process with the waterfowl management community. The resulting management objective serves to integrate and balance multiple competing objectives for pintail harvest management, including minimizing closed seasons, maximizing seasons with liberal season lengths, and providing for a 3-bird bag limit, while minimizing large changes in regulations.

The adaptive management protocol considers a range of regulatory alternatives for pintail harvest management that

Table 7 – Black duck optimal regulatory strategies^a for Canada and the United States for the 2025 hunting season predicated on a liberal alternative selected by Canada and a moderate alternative selected by the United States the previous season. This strategy is based on current regulatory alternatives, predicted harvest rates, an integrated population model, the objective of achieving 98% of the maximum long-term cumulative harvest, and to share the allocated harvest equitably between countries (i.e., parity). The parity constraint was temporarily altered for the 2025 policy optimization so that if one country is under its most liberal alternative (e.g., a liberal alternative in Canada), the other country cannot be penalized by the parity constraint. The shaded cell indicates the regulatory prescription for each country for the 2025 season.

BPOP ^b	Canada	United States
0.05	C	C
0.1	R	C
0.15	R	C
0.2	R	C
0.25	L	R
0.3	L	R
0.35	L	R
0.4	L	R
0.45	L	R
0.5	L	R
0.55	L	R
0.6	L	R
0.65	L	R
0.7	L	M
0.75	L	M
0.8	L	M
0.85	L	M
0.9	L	M
0.95	L	M
1	L	M

^a C = closed season, R = restrictive, M = moderate, L = liberal.

^b Observed black duck breeding population size (in millions).

includes a closed season, 1-bird, 2-bird, or 3-bird daily bag limit. The maximum pintail season length depends on the general duck season framework (characterized as liberal, moderate, or restrictive and varying by Flyway) specified by mallard or multi-stock AHM frameworks. An optimal pintail regulation is calculated under the assumption of a liberal mallard or multi-stock season length in all Flyways.

The optimal regulatory strategy for the 2025 hunting season was calculated for northern pintails using: (1) an objective to maximize long-term cumulative harvest; (2) current regulatory alternatives and the closed-season constraint; and (3) the integrated population model for northern pintails. Assuming that harvest management adhered to this strategy (and that current models accurately reflect population dynamics), pintail breeding-population size would be expected to average 2.01 million with a mean observed harvest of 467,000 birds. Based on an observed 2024 breeding population size of 1.97 million pintails observed at a mean latitude of 57.02 degrees, the optimal regulatory choice for the 2025 hunting season for all four Flyways is the liberal regulatory alternative with a 3-bird daily bag limit (Table 8).

Table 8 – Northern pintail optimal regulatory strategy^a for the 2025 hunting season predicated on a liberal season length. This strategy is based on current regulatory alternatives, a new integrated population model, and the objective of maximizing long-term cumulative harvest constrained to provide for an open hunting season when the observed breeding population is ≥ 1.2 million birds. The shaded cell indicates the regulatory prescription for 2025.

BPOP ^b	Mean latitude ^c																				
	54	54.25	54.5	54.75	55	55.25	55.5	55.75	56	56.25	56.5	56.75	57	57.25	57.5	57.75	58	58.25	58.5	58.75	59
≤ 1	C	C	C	C	C	C	C	C	C	C	C	C	C	C	C	C	C	C	C	C	C
1.1	C	C	C	C	C	C	C	C	C	C	C	C	C	C	C	C	C	C	C	C	C
1.2	L1	L1	L1	L1	L1	L1	L1	L1	L1	L1	L1	L1	L1	L1	L1	L1	L1	L1	L1	L1	L1
1.3	L1	L1	L1	L1	L1	L1	L1	L1	L1	L1	L1	L1	L1	L1	L1	L1	L1	L1	L1	L1	L1
1.4	L1	L1	L1	L1	L1	L1	L1	L1	L1	L1	L1	L1	L1	L1	L1	L1	L1	L1	L1	L1	L1
1.5	L1	L1	L1	L1	L1	L1	L1	L1	L1	L1	L1	L1	L1	L1	L1	L1	L1	L2	L3	L3	L3
1.6	L1	L1	L1	L1	L1	L1	L1	L1	L1	L1	L1	L1	L2	L3	L3	L3	L3	L3	L3	L3	L3
1.7	L1	L1	L1	L1	L1	L1	L1	L1	L2	L3	L3	L3	L3	L3	L3	L3	L3	L3	L3	L3	L3
1.8	L1	L1	L2	L3	L3	L3	L3	L3	L3	L3	L3	L3	L3	L3	L3	L3	L3	L3	L3	L3	L3
1.9	L3	L3	L3	L3	L3	L3	L3	L3	L3	L3	L3	L3	L3	L3	L3	L3	L3	L3	L3	L3	L3
2	L3	L3	L3	L3	L3	L3	L3	L3	L3	L3	L3	L3	L3	L3	L3	L3	L3	L3	L3	L3	L3
2.1	L3	L3	L3	L3	L3	L3	L3	L3	L3	L3	L3	L3	L3	L3	L3	L3	L3	L3	L3	L3	L3
2.2	L3	L3	L3	L3	L3	L3	L3	L3	L3	L3	L3	L3	L3	L3	L3	L3	L3	L3	L3	L3	L3
2.3	L3	L3	L3	L3	L3	L3	L3	L3	L3	L3	L3	L3	L3	L3	L3	L3	L3	L3	L3	L3	L3
2.4	L3	L3	L3	L3	L3	L3	L3	L3	L3	L3	L3	L3	L3	L3	L3	L3	L3	L3	L3	L3	L3
2.5	L3	L3	L3	L3	L3	L3	L3	L3	L3	L3	L3	L3	L3	L3	L3	L3	L3	L3	L3	L3	L3
2.6	L3	L3	L3	L3	L3	L3	L3	L3	L3	L3	L3	L3	L3	L3	L3	L3	L3	L3	L3	L3	L3
2.7	L3	L3	L3	L3	L3	L3	L3	L3	L3	L3	L3	L3	L3	L3	L3	L3	L3	L3	L3	L3	L3
2.8	L3	L3	L3	L3	L3	L3	L3	L3	L3	L3	L3	L3	L3	L3	L3	L3	L3	L3	L3	L3	L3
2.9	L3	L3	L3	L3	L3	L3	L3	L3	L3	L3	L3	L3	L3	L3	L3	L3	L3	L3	L3	L3	L3
≥ 3	L3	L3	L3	L3	L3	L3	L3	L3	L3	L3	L3	L3	L3	L3	L3	L3	L3	L3	L3	L3	L3

^a C = closed season, L1 = liberal season with 1-bird daily bag limit, L2 = liberal season with 2-bird daily bag limit, L3 = liberal season with 3-bird daily bag limit.

^b Observed northern pintail breeding population size (in millions) from the WBPBS (strata 1–18, 20–50, 75–77).

^c Mean latitude (in degrees) is the average latitude of the WBPBS strata weighted by population size.

9.3 Scaup

The USFWS implemented an AHM decision-making framework to inform scaup harvest regulations in 2008 (Boomer and Johnson 2007). Prior to the implementation of the SEIS 2013, the scaup AHM protocol first derived optimal harvest levels which were then used to determine the recommended regulatory package. Each year, an optimization was performed to identify the optimal harvest level based on updated scaup population parameters. The harvest regulation was then determined by comparing the optimal harvest level to the harvest thresholds corresponding to restrictive, moderate, and liberal packages (see Boomer et al. 2007). Due to the changes in decision timing associated with the SEIS, these procedures are not possible because decision makers would have to condition their regulatory decision on the harvest levels observed during the previous hunting season and this information would not be available. As a result, the decision variable (harvest) in the scaup optimization was changed from harvest levels to a set of packages with associated expected harvest levels in the updated optimization methods. We used the thresholds identified in Boomer et al. (2007) to specify expected harvest levels for each package (Table 9). To account for partial controllability of the scaup harvest, we assumed that the harvest under each package could be represented with a normal distribution with the mean set to the expected harvest level, assuming a coefficient of variation equal to 20%.

Initial scaup regulatory alternatives associated with restrictive, moderate, and liberal packages were developed based on a simulation of an optimal policy derived under an objective to achieve 95% of the maximum, long-term cumulative harvest (Boomer et al. 2007). This objective resulted in a strategy less sensitive to small changes in population size compared to a strategy derived under an objective to achieve 100% of the maximum, long-term cumulative harvest and allowed for some harvest opportunity at relatively low population sizes. The USFWS worked with the Flyways to specify Flyway-specific regulatory alternatives to achieve the allowable harvest thresholds corresponding to each package. At this time, the USFWS also agreed to consider “hybrid season” options that would be available to all Flyways for the restrictive and moderate packages. Hybrid seasons allow daily bag limits to vary for certain continuous portions of the scaup season length. In 2008, restrictive, moderate, and liberal scaup regulatory alternatives were defined and implemented in all four Flyways. Subsequent feedback from the Flyways led the USFWS to further clarify criteria associated with the establishment of “hybrid seasons” and to allow additional modifications of the alternatives for each Flyway resulting in updated regulatory alternatives that were adopted in 2009. Because of the considerable uncertainty involved with predicting scaup harvest, the USFWS and the Flyways agreed to keep these packages in place for at least 3 years. In 2013, the moderate packages for the Mississippi and Central Flyways were modified to include a 3-bird daily bag limit.

The lack of scaup demographic information over a sufficient time frame and at a continental scale precludes the use of a traditional balance equation to represent scaup population and harvest dynamics. As a result, we used a discrete-time, stochastic, logistic-growth population model to represent changes in scaup abundance, while explicitly accounting for scaling issues associated with the monitoring data. Details describing the modeling and assessment framework that has been developed for scaup can be found in Appendix I and in Boomer and Johnson (2007).

We updated the scaup assessment based on the current model formulation and data extending from 1974 through 2024,

Table 9 – Regulatory alternatives^a and total expected harvest levels corresponding to the closed, restrictive, moderate, and liberal packages considered in the scaup adaptive harvest management decision framework.

Package	Atlantic	Mississippi	Central	Pacific	Expected Harvest ^c
Closed					0.04
Restrictive	20(2)/40(1) ^b	45(2)/15(1) ^b	39(2)/35(1) ^b	86(2)	0.20
Moderate	60(2)	60(3)	74(3)	86(3)	0.35
Liberal	60(4)	60(4)	74(6)	107(7)	0.60

^a Season length in days (daily bag limit); these alternatives assume an overall liberal adaptive harvest management framework as determined by the status of mallards or multiple stocks in the Atlantic Flyway.

^b Multiple day and daily bag limit combinations refer to hybrid seasons which allow for different daily bag limits over a continuous season length.

^c Total harvest in millions (Canada and United States combined).

while predicting the unobserved 2020–21 breeding population sizes. As in past analyses, the state-space formulation and Bayesian analysis framework provided reasonable fits to the observed breeding population and total harvest estimates with realistic measures of variation. The posterior mean estimate of the intrinsic rate of increase (r) is 0.13 while the posterior mean estimate of the carrying capacity (K) is 9.13 million birds. The posterior mean estimate of the scaling parameter (q) is 0.76, ranging between 0.69 and 0.84 with 95% probability.

An optimal regulatory strategy for the 2025 hunting season was calculated for scaup using: (1) an objective to achieve 95% of the maximum, long-term cumulative harvest; (2) current regulatory alternatives; and (3) the current population model and updated parameter estimates. The resulting regulatory strategy includes options conditional on the regulatory alternative selected the previous hunting season. We simulated the use of this regulatory strategy to determine expected performance characteristics. Assuming that harvest management adhered to this strategy (and that current model parameters accurately reflect population dynamics), breeding-population size would be expected to average 5.13 million (SD = 0.94 million). Based on a restrictive regulatory alternative selected for the 2024 hunting season and an observed 2024 breeding population size of 4.07 million scaup, the optimal regulatory choice for the 2025 hunting season for all four Flyways is the restrictive regulatory alternative (Table 10).

9.4 Eastern Mallards

Waterfowl harvest in the Atlantic Flyway has exhibited several characteristics that have differentiated it from harvest in other Flyways, including unique population dynamics of the widely harvested mallard. An Eastern Mallard Adaptive Harvest Management Plan was used to set the general duck hunting season in the Atlantic Flyway from 1997 through 2018. This strategy addressed concerns that mid-continent mallards did not represent eastern populations and did not include population estimates from the large breeding population in eastern North America. The Atlantic Flyway has since moved away from a single-species strategy to set general duck regulations to a Multi-stock Adaptive Harvest Management strategy. This framework has been used since 2019 to set general duck season regulations based on the status of four species (Johnson et al. 2019). Mallards are not represented in the suite of species used in Multi-stock AHM, but are still an important bird in the bag of Atlantic Flyway hunters, hence the Atlantic Flyway Council and the U.S. Fish and Wildlife Service agreed to develop a state dependent harvest strategy for eastern mallards.

The fundamental objectives of the new strategy are to sustain an eastern mallard population that meets legal mandates (e.g., Migratory Bird Treaty Act) and provide consumptive and non-consumptive uses indefinitely. Relative to consumptive uses, the strategy is designed to maximize long-term harvest, maximize liberal hunting seasons, minimize closed seasons, and minimize annual regulatory changes. The new strategy is predicated on an IPM of eastern mallard population dynamics. The goals and objectives of the eastern mallard AHM framework were developed through a formal consultation process with representatives from the USFWS and Atlantic Flyway Council. Details describing the development of the technical and policy elements are provided in Roberts et al. (2022).

The Eastern Mallard AHM strategy includes a set of expected harvest rate distributions defined as 4 regulatory alternatives (liberal, moderate, restrictive, and closed). These alternatives are variations in the bag limit of mallards as the season length is set by Multi-stock AHM. The bag limits are 4 mallards (limit of 2 hens), 2 mallards (limit of 1 hen), 1 mallard, or closed for liberal, moderate, restrictive, and closed seasons respectively. Expected harvest rates under each regulatory alternative are updated annually when new information is available conditional on the specific regulatory alternative implemented the previous year. This strategy only applies to Atlantic Flyway states, whereas regulations for eastern mallards are established independently by the Canadian Wildlife Service. The optimal strategy will be determined each year through the AHM protocol.

The AHM mallard population model is based on spring breeding-ground abundance as estimated by the integrated Eastern Waterfowl Survey and Atlantic Flyway Breeding Waterfowl Survey. Fall age ratios are estimated using harvest age ratios derived from the USFWS and CWS parts collection surveys, adjusted for differential vulnerability. Age- and sex-specific harvest rates are based on recoveries of mallards banded after the breeding season (July–September) in Canada and the Atlantic Flyway adjusted by reporting rates. Band recoveries of mallards banded in Canada and the Atlantic Flyway, both after the breeding season and after the hunting season (15 January–31 March) were used to estimate age- and sex-specific seasonal survival rates using a 2-season banding model (Devers et al. 2021).

Table 10 – Scaup optimal regulatory strategy^a for the 2025 hunting season. This strategy is based on the current scaup population model and an objective to achieve 95% of the maximum, long-term cumulative harvest. Predicated on a restrictive regulatory alternative selected the previous year (2024), the shaded cell indicates the regulatory prescription for the 2025 hunting season.

BPOP ^b	Previous Regulation			
	Closed	Restrictive	Moderate	Liberal
≤3	C	C	C	C
3.1	R	C	C	C
3.2	R	R	C	C
3.3	R	R	R	C
3.4	R	R	R	C
3.5	R	R	R	R
3.6	R	R	R	R
3.7	R	R	R	R
3.8	R	R	R	R
3.9	R	R	R	R
4	R	R	R	R
4.1	R	R	R	R
4.2	R	R	R	R
4.3	R	R	R	R
4.4	M	R	R	R
4.5	M	M	R	R
4.6	M	M	M	R
4.7	M	M	M	R
4.8	M	M	M	M
4.9	M	M	M	M
5	M	M	M	M
5.1	M	M	M	M
5.2	M	M	M	M
5.3	M	M	M	M
5.4	M	M	M	M
5.5	M	M	M	M
5.6	M	M	M	M
5.7	M	M	M	M
5.8	M	M	M	M
5.9	L	M	M	M
6	L	L	M	M
6.1	L	L	L	M
6.2	L	L	L	M
≥6.3	L	L	L	L

^a C = closed season, R = restrictive, M = moderate, L = liberal.

^b Estimated scaup breeding population (in millions) observed in the WBPHS (strata 1–18, 20–50, 75–77).

The eastern mallard integrated population model is structured to include multiple features of population dynamics deemed to be important to mallard abundance and trends. Two hypotheses concerning survival are integrated in the model. One states that mallard population growth is limited by harvest because hunting mortality is additive to natural mortality. As the effect of harvest mortality, or additivity ($a1$), increases, annual survival decreases and limits population growth. The other hypothesis states that there is a declining trend in survival of both juvenile cohorts through time ($a3$). The current AHM framework incorporates each of these hypotheses into a single parametric model of survival for each cohort. In addition, a parametric model of reproduction is included that states annual reproduction is a function of mallard population size, and as the population size increases reproduction decreases. This hypothesis examines the effect of density dependence ($c1$) on population growth. Estimates of all parameters are updated with current year's monitoring data and are used to establish annual harvest regulations.

The optimal regulatory strategy for the 2025 hunting season was calculated using: (1) the mallard harvest objective (98% of long-term cumulative harvest); (2) current regulatory alternatives; (3) current parameter estimates; (4) 2024 estimate of 1.17 million breeding mallards in the survey area; and (5) the 2024 regulations (mallard bag limit of 4 with a 2-hen restriction). The optimal regulatory choice for the 2025 hunting season is the liberal alternative (Table 11).

10 EMERGING ISSUES IN ADAPTIVE HARVEST MANAGEMENT

Learning occurs passively with current AHM protocols as annual comparisons of model predictions to observations from monitoring programs are used to update relative beliefs about system responses to management (Johnson et al. 2002) and as model parameters are updated based on an assessment of the most recent monitoring data (Boomer and Johnson 2007, Johnson et al. 2007). However, learning can also occur as decision-making frameworks are evaluated to determine if objectives are being achieved, have changed, or if other aspects of the decision problem are adequately being addressed. Often the feedback resulting from this process results in a form of “double-loop” learning (Lee 1993) that offers the opportunity to adapt decision-making frameworks in response to a shifting decision context, novel or emerging management alternatives, or a need to revise assumptions and models that may perform poorly or need to account for new information. Adaptive management depends on this iterative process to ensure that decision-making protocols remain relevant in evolving biological and social systems. Throughout the waterfowl harvest management community, substantial progress has been made to outline the important issues to be considered in the revision of each AHM protocol (Johnson et al. 2015). Recent shocks (COVID 19 and budgetary issues) to the harvest management system have raised concerns within the HMWG that current decision processes have become less resilient and have limited our ability to respond and adapt to external forcings or large-scale, directional system change. In response to these emerging issues, the HMWG has been focusing efforts on the evolving needs of AHM and the role of the working group in planning for and executing the double- and triple-loop learning (Kwon and Nicolaidis 2017) phases of AHM in relation to current decision-making frameworks.

The HMWG continues to explore the technical challenges resulting from the impacts of large-scale habitat and environmental change on the decision-making frameworks used to inform waterfowl harvest management. We anticipate that large-scale system change will exacerbate most forms of uncertainty that affect waterfowl AHM, but we believe that the elements of the current AHM framework provide the necessary structure for coping with these changing systems (Nichols et al. 2011). Recent efforts have investigated the importance of accounting for time-dependence when deriving harvest policy for non-stationary systems (Tucker and Runge 2021). We believe this work may lay the groundwork to explore formal adaptive management approaches to dealing with uncertain climate futures when informing annual harvest regulations.

The 2023 HMWG meeting focused on revisions to northern pintail AHM, time-dependent solutions to optimization problems, and problem framing of harvest management issues related to non-mallard stocks at continental scales (U.S. Fish and Wildlife Service 2023). At the conclusion of the 2023 annual meeting, the HMWG reviewed the approved set of fiscal year (FY2024) priorities while planning for future work. Based on these deliberations, the HMWG agreed to continue work on the high priority projects listed in the HMWG Priorities for the 2025 Fiscal year. This work would continue to focus on reconsidering North American duck harvest management and evaluating how decreases in monitoring effort would impact AHM decision-making frameworks (Appendix C).

Table 11 – Eastern mallard optimal regulatory strategy^a for the Atlantic Flyway for the 2025 hunting season. This strategy is based on the eastern mallard population model and an objective to achieve 98% of the maximum, long-term cumulative harvest. Predicated on the current eastern mallard population estimate and the liberal regulatory alternative selected the previous year (2024), the shaded cell indicates the regulatory prescription for the 2025 hunting season.

BPOP ^b	Previous Regulation			
	Closed	Restrictive	Moderate	Liberal
≤150	C	C	C	C
200	R	C	C	C
250	R	R	R	R
300	R	R	R	R
350	R	R	R	R
400	R	R	R	R
450	R	R	R	R
500	R	R	R	R
550	R	R	R	R
600	M	R	R	R
650	M	M	M	R
700	M	M	M	M
750	M	M	M	M
800	M	M	M	M
850	M	M	M	M
900	M	M	M	M
950	M	M	M	M
1000	L	M	M	M
1050	L	L	M	M
1100	L	L	L	M
1150	L	L	L	L
1200	L	L	L	L
1250	L	L	L	L
≥1300	L	L	L	L

^a Eastern mallard regulatory alternatives are conditional on season lengths determined by the Atlantic Flyway multi-stock AHM protocol and include: C = closed season, R = restrictive (1-mallard bag), M = moderate (2-mallard bag, limited to 1 hen), and L = liberal (4-mallard bag, limited to 2 hens).

^b Eastern mallard breeding population size in thousands.

LITERATURE CITED

- Anderson, D. R. 1975. Optimal Exploitation Strategies for an Animal Population in a Markovian Environment: A Theory and an Example. *Ecology* 56:1281–1297.
- Anderson, D. R., and K. P. Burnham. 1976. Population ecology of the mallard. VI. The effect of exploitation on survival. U.S. Fish and Wildlife Service Resource Publication. 128. 66pp.
- Arnold, T. W., R. G. Clark, D. N. Koons, and M. Schaub. 2018. Integrated population models facilitate ecological understanding and improved management decisions. *The Journal of Wildlife Management* 82:266–274.
- Balkcom, G. D., P. R. Garrettson, and P. I. Padding. 2010. Predicting wood duck harvest rates in Eastern North America. *Journal of Wildlife Management* 74:1575–1579.
- Bartzen, B. A., and K. W. Dufour. 2017. Northern Pintail (*Anas acuta*) survival, recovery, and harvest rates derived from 55 years of banding in Prairie Canada, 1960-2014. *Avian Conservation and Ecology* 12.
- Besbeas, P., S. N. Freeman, B. J. T. Morgan, and E. A. Catchpole. 2002. Integrating Mark–Recapture–Recovery and Census Data to Estimate Animal Abundance and Demographic Parameters. *Biometrics* 58:540–547.
- Blohm, R. J. 1989. Introduction to harvest – understanding surveys and season setting. *Proceedings of the International Waterfowl Symposium* 6:118–133.
- Boomer, G. S., P. R. Garrettson, and N. L. Zimpfer. 2023. Mid-continent mallard reporting rate estimation. Unpublished Report. U.S. Fish and Wildlife Service, Patuxent Wildlife Research Center, Laurel, MD. 54pp.
- Boomer, G. S., and F. A. Johnson. 2007. A proposed assessment and decision-making framework to inform scaup harvest management. Unpublished Report. U.S. Fish and Wildlife Service, Laurel, MD. 26pp.
- Boomer, G. S., F. A. Johnson, M. D. Koneff, T. A. Sanders, and R. E. Trost. 2007. A process to determine scaup regulatory alternatives. Unpublished Scoping Document. U.S. Fish and Wildlife Service, Laurel, MD. 20pp.
- Boomer, G. S., F. A. Johnson, and G. S. Zimmerman. 2015. Adaptive harvest management: adjustments for SEIS 2013. U. S. Department of Interior, Washington, D. C. 21pp.
- Boomer, G. S., M. C. Runge, and E. A. Osnas. 2024. An Integrated Population Model for Northern Pintail Adaptive Harvest Management. Technical Report. U.S. Fish and Wildlife Service, U.S. Department of Interior. Washington D.C. 40pp.
- Boomer, G. S., G. S. Zimmerman, P. R. Garrettson, M. D. Koneff, T. A. Sanders, K. D. Magruder, and J. A. Royle. 2013. Band reporting probabilities for mallards recovered in the United States and Canada. *Journal of Wildlife Management* 77:1059–1066.
- Brasher, M. G., T. W. Arnold, J. H. Devries, and R. M. Kaminski. 2006. Breeding-Season Survival of Male and Female Mallards in Canada’s Prairie-Parklands. *The Journal of Wildlife Management* 70:805–811.
- Brooks, S. P., and A. Gelman. 1998. Alternative methods for monitoring convergence of iterative simulations. *Journal of Computational and Graphical Statistics* 7:434–455.
- Brownie, C., D. R. Anderson, K. P. Burnham, and D. S. Robson. 1985. Statistical inference from band recovery data - a handbook, 2nd Ed. U.S. Fish and Wildlife Service Resource Publication No. 156:1:305.
- Burham, K. P., and D. R. Anderson. 1984. Tests of Compensatory vs. Additive Hypotheses of Mortality in Mallards. *Ecology* 65:105–112.
- Burnham, K. P., G. C. White, and D. R. Anderson. 1984. Estimating the effect of hunting on annual survival rates of adult mallards. *Journal of Wildlife Management* 48:350–361.
- Conroy, M., and D. Krementz. 1990. A review of the evidence for the effects of hunting on American black duck populations. *Transactions of the North American Wildlife and Natural Resources Conference* 55:501–517.

- Conroy, M. J. 2010. Technical support for adaptive harvest management for American black ducks. Unpublished Final Report. Cooperative Fish and Wildlife Research Unit, U.S. Geological Survey, Warnell School of Forestry and Natural Resources, University of Georgia, Athens, GA.
- Cooch, E. G., M. Guillemain, G. S. Boomer, J.-D. Lebreton, and J. D. Nichols. 2014. The effects of harvest on waterfowl populations. *Wildfowl Special Issue* 4:220–276.
- Devers, P. K., R. L. Emmet, G. S. Boomer, G. S. Zimmerman, and J. A. Royle. 2021. Evaluation of a two-season banding program to estimate and model migratory bird survival. *Ecological Applications* 31:e02425.
- Fackler, P. 2011. User's Guide, MDPSOLVE: A MATLAB Toolbox for Solving Markov Decision Problems with Dynamic Programming.
- Gabry, J., R. Češnovar, and A. Johnson. 2024. cmdstanr: R Interface to 'CmdStan'.
- Garrettson, P. R., R. V. Raftovich, J. E. Hines, and G. S. Zimmerman. 2013. Band reporting probabilities of mallards, American black ducks, and wood ducks in eastern North America. *Journal of Wildlife Management* 78:50–57.
- Henny, C. J., and K. P. Burnham. 1976. A reward band study of mallards to estimate reporting rates. *Journal of Wildlife Management* 40:1–14.
- Heusmann, H. W., and J. R. Sauer. 2000. The northeastern states' waterfowl breeding population survey. *Wildlife Society Bulletin* 28:355–364.
- Hodges, J. L., J. G. King, B. Conant, and H. A. Hanson. 1996. Aerial surveys of waterbirds in Alaska 1975–94: population trends and observer variability. National Biological Service, U.S. Department of the Interior Information and Technology Report 4, Washington, D.C.
- Hyndman, R. J., and G. Athanasopoulos. 2018. *Forecasting: principles and practice*, 2nd edition. OTexts: Melbourne, Australia, OTexts.com/fpp2. Accessed on 14 July 2020.
- Johnson, F. A. 2003. Population dynamics of ducks other than mallards in mid-continent North America. Draft. U.S. Fish and Wildlife Service, U.S. Department of the Interior, Washington, D.C. 15pp.
- Johnson, F. A., G. S. Boomer, and T. A. Sanders. 2007. A proposed protocol for the adaptive harvest management of mallards breeding in Western North America. Unpublished Report. U.S. Fish and Wildlife Service, Laurel, MD. 33pp.
- Johnson, F. A., G. S. Boomer, B. K. Williams, J. D. Nichols, and D. J. Case. 2015. Multilevel Learning in the Adaptive Management of Waterfowl Harvests: 20 Years and Counting. *Wildlife Society Bulletin* 39:9–19.
- Johnson, F. A., P. L. Fackler, G. S. Boomer, G. S. Zimmerman, B. K. Williams, J. D. Nichols, and R. M. Dorazio. 2016. State-dependent resource harvesting with lagged information about system states. *PLoS ONE* 11:1–21.
- Johnson, F. A., W. L. Kendall, and J. A. Dubovsky. 2002. Conditions and limitations on learning in the adaptive management of mallard harvests. *Wildlife Society Bulletin* 30:176–185.
- Johnson, F. A., C. T. Moore, W. L. Kendall, J. A. Dubovsky, D. F. Caithamer, J. Kelley, J. R., and B. K. Williams. 1997. Uncertainty and the management of mallard harvests. *Journal of Wildlife Management* 61:202–216.
- Johnson, F. A., M. A. Walters, and G. S. Boomer. 2012. Allowable levels of take for the trade in Nearctic songbirds. *Ecological Applications* 22:1114–1130.
- Johnson, F. A., B. K. Williams, J. D. Nichols, J. E. Hines, W. L. Kendall, G. W. Smith, and D. F. Caithamer. 1993. Developing an adaptive management strategy for harvesting waterfowl in North America. *Transactions of the North American Wildlife and Natural Resources Conference* 58:565–583.
- Johnson, F. A., B. K. Williams, and P. R. Schmidt. 1996. Adaptive decision-making in waterfowl harvest and habitat management. *Proceedings of the International Waterfowl Symposium* 7:26–33.

- Johnson, F. A., G. S. Zimmerman, M. T. Huang, P. I. Padding, G. D. Balkcom, M. C. Runge, and P. K. Devers. 2019. Multi-species duck harvesting using dynamic programming and multi-criteria decision analysis. *Journal of Applied Ecology* 56:1447–1459.
- Koons, D. N., T. V. Riecke, G. S. Boomer, B. S. Sedinger, J. S. Sedinger, P. J. Williams, and T. W. Arnold. 2022. A niche for null models in adaptive resource management. *Ecology and Evolution* 12:e8541.
- Kwon, C.-k., and A. Nicolaidis. 2017. Managing Diversity Through Triple-Loop Learning: A Call for Paradigm Shift. *Human Resource Development Review* 16:85–99.
- Lee, K. N. 1993. *Compass and Gyroscope: Integrating Science and Politics for the Environment*. Island Press, Washington, D.C.
- Martin, E. M., and S. M. Carney. 1977. Population ecology of the mallard. IV. A review of duck hunting regulations, activity, and success, with special reference to the mallard. U.S. Fish and Wildlife Service, Washington D.C.
- Martin, F., R. Pospahala, and J. D. Nichols, 1979. Assessment and population management of North American migratory birds. Pages 187–239 in J. Cairns, G. P. Patil, and W. E. Waters, editors. *Environmental Biomonitoring, Assessment, Prediction, and Management—Certain Case Studies and Related Quantitative Issues*. International Co-operative Publishing House, Burtonsville, MD, USA.
- MATLAB. 2016. Version 9.0.0.341360 (R2016a). The MathWorks Inc., Natick, Massachusetts.
- Meyer, R., and R. B. Millar. 1999. BUGS in Bayesian stock assessments. *Canadian Journal of Fisheries and Aquatic Sciences* 56:10078–1086.
- Millar, R. B., and R. Meyer. 2000. Non-linear state space modeling of fisheries biomass dynamics by using Metropolis-Hastings within Gibbs sampling. *Applied Statistics* 49:327–342.
- Nichols, J. D., R. J. Blohm, R. E. Reynolds, R. E. Trost, J. E. Hines, and J. P. Bladen. 1991. Band Reporting Rates for Mallards with Reward Bands of Different Dollar Values. *The Journal of Wildlife Management* 55:119–126.
- Nichols, J. D., F. A. Johnson, and B. K. Williams. 1995a. Managing North American waterfowl in the face of uncertainty. *Annual Review of Ecology and Systematics* 26:177–199.
- Nichols, J. D., F. A. Johnson, B. K. Williams, and G. S. Boomer. 2015. On formally integrating science and policy: walking the walk. *Journal of Applied Ecology* 52:539–543.
- Nichols, J. D., M. D. Koneff, P. J. Heglund, M. G. Knutson, M. E. Seamans, J. E. Lyons, J. M. Morton, M. T. Jones, G. S. Boomer, and B. K. Williams. 2011. Climate change, uncertainty, and natural resource management. *Journal of Wildlife Management* 75:6–18.
- Nichols, J. D., R. E. Reynolds, R. J. Blohm, R. E. Trost, J. E. Hines, and J. P. Bladen. 1995b. Geographic variation in band reporting rates for mallards based on reward banding. *Journal of Wildlife Management* 59:697–708.
- Niel, C., and J.-D. Lebreton. 2005. Using demographic invariants to detect overharvested bird populations from incomplete data. *Conservation Biology* 19:826–835.
- Osnas, E. E., G. S. Boomer, J. H. Devries, and M. C. Runge. 2021. Decision-support framework for linking regional-scale management actions to continental-scale conservation of wide-ranging species. U.S. Geological Survey Open-File Report 2020–1084 pages 1–31.
- Osnas, E. E., Q. Zhao, M. C. Runge, and G. S. Boomer. 2016. Cross-seasonal effects on waterfowl productivity: Implications under climate change. *The Journal of Wildlife Management* 80:1227–1241.
- Padding, P. I., and J. A. Royle. 2012. Assessment of bias in US waterfowl harvest estimates. *Wildlife Research* 39:336–342.
- Padding, P. I., G. S. Zimmerman, M. T. Huang, G. D. Balkcom, and P. K. Devers. 2018. A multi-stock adaptive harvest management protocol for informing annual harvest regulations in the Atlantic Flyway. Unpublished Final Report. U.S. Fish and Wildlife Service Division of Migratory Bird Management and the Atlantic Flyway.

- Plummer, M., 2003. JAGS: A program for analysis of Bayesian graphical models using Gibbs sampling. Pages 1–10 *in* K. Hornik, F. Leisch, and A. Zeileis, editors. Proceedings of the 3rd international workshop on distributed statistical computing (DSC 2003). Vienna, Austria.
- R Core Team. 2023. R: A Language and Environment for Statistical Computing. R Foundation for Statistical Computing, Vienna, Austria.
- Raftovich, R. V., K. K. Fleming, S. C. Chandler, and C. M. Cain. 2023. Migratory Bird Hunting Activity and Harvest during the 2021–22 and 2022–23 Hunting Seasons.
- Raveling, D. G., and M. E. Heitmeyer. 1989. Relationships of Population Size and Recruitment of Pintails to Habitat Conditions and Harvest. *The Journal of Wildlife Management* 53:1088–1103.
- Rice, M. B., D. A. Haukos, J. A. Dubovsky, and M. C. Runge. 2010. Continental Survival and Recovery Rates of Northern Pintails Using Band-Recovery Data. *The Journal of Wildlife Management* 74:778–787.
- Richkus, K. D., F. C. Rohwer, and M. J. Chamberlain. 2005. Survival and Cause-Specific Mortality of Female Northern Pintails in Southern Saskatchewan. *The Journal of Wildlife Management* 69:574–581.
- Riecke, T. V., M. G. Lohman, B. S. Sedinger, T. W. Arnold, C. L. Feldheim, D. N. Koons, F. C. Rohwer, M. Schaub, P. J. Williams, and J. S. Sedinger. 2022a. Density-dependence produces spurious relationships among demographic parameters in a harvested species. *Journal of Animal Ecology* 91:2261–2272.
- Riecke, T. V., B. S. Sedinger, T. W. Arnold, D. Gibson, D. N. Koons, M. G. Lohman, M. Schaub, P. J. Williams, and J. S. Sedinger. 2022b. A hierarchical model for jointly assessing ecological and anthropogenic impacts on animal demography. *Journal of Animal Ecology* 91:1612–1626.
- Roberts, A., J. Hostetler, J. Stiller, P. K. Devers, W. Link, M. Huang, and G. S. Boomer. 2022. Eastern mallard adaptive harvest management strategy. U. S. Department of Interior, Washington, D. C. 32pp.
- Runge, M. C., and G. S. Boomer. 2005. Population dynamics and harvest management of the continental northern pintail population. Unpublished Report. U.S. Geological Survey, Patuxent Wildlife Research Center, Laurel, MD. 42pp.
- Runge, M. C., F. A. Johnson, J. A. Dubovsky, W. L. Kendall, J. Lawrence, and J. Gammonley. 2002. A revised protocol for the adaptive harvest management of mid-continent mallards. U.S. Fish and Wildlife Service, U.S. Department of the Interior Technical report, Washington, D.C.
- Runge, M. C., W. L. Kendall, and J. D. Nichols, 2004. Exploitation. Pages 303–328 *in* W. J. Sutherland, I. Newton, and R. Green, editors. *Bird Ecology and Conservation: A Handbook of Techniques*. Oxford University Press, Inc., Oxford, UK.
- Schaefer, M. B. 1954. Some aspects of the dynamics of populations important to the management of commercial marine fisheries. *Bulletin of the Inter-American Tropical Tuna Commission* 1:25–56.
- Smith, G. W. 1995. A critical review of the aerial and ground surveys of breeding waterfowl in North America. National Biological Service, U.S. Department of the Interior Biological Science Report 5, Washington, D.C.
- Spiegelhalter, D. J., A. Thomas, N. Best, and D. Lunn. 2003. WinBUGS 1.4 User manual. MRC Biostatistics Unit, Institutes of Public Health, Cambridge, UK.
- Stan. 2024. Stan Modeling Language Users Guide and Reference Manual 2.34. Stan Development Team., <https://mc-stan.org>.
- Tucker, A. M., and M. C. Runge. 2021. Optimal strategies for managing wildlife harvest under system change. *Journal of Wildlife Management* 85:847–854.
- U.S. Department of the Interior. 2013. Final Supplemental Environmental Impact Statement: Issuance of Annual Regulations Permitting the Hunting of Migratory Birds. U.S. Fish and Wildlife Service, Washington, D.C. 418pp.

- U.S. Fish and Wildlife Service. 2000. Adaptive harvest management: 2000 duck hunting season. U.S. Department of Interior, Washington, D.C. 43pp.
- U.S. Fish and Wildlife Service. 2001. Framework-date extensions for duck hunting in the United States: projected impacts & coping with uncertainty. U.S. Department of Interior, Washington, D.C. 8pp.
- U.S. Fish and Wildlife Service. 2002. Adaptive harvest management: 2002 duck hunting season. U.S. Department of Interior, Washington, D.C. 34pp.
- U.S. Fish and Wildlife Service. 2010. Northern Pintail Harvest Strategy. U.S. Department of Interior, Fish and Wildlife Service, Division of Migratory Bird Management, Washington, D.C. 20pp.
- U.S. Fish and Wildlife Service. 2017. Adaptive harvest management: 2018 hunting season. U.S. Department of Interior, Washington, D.C. 58pp.
- U.S. Fish and Wildlife Service. 2019. Waterfowl population status, 2019. U.S. Department of Interior, Washington, D.C.
- U.S. Fish and Wildlife Service. 2020. Harvest Management Working Group: 2020 Annual Meeting Report. U.S. Department of Interior, Washington, D.C. 32pp.
- U.S. Fish and Wildlife Service. 2023. Harvest Management Working Group: 2023 Annual Meeting Report. U.S. Department of Interior, Washington, D.C. 41pp.
- Vehtari, A., A. Gelman, D. Simpson, B. Carpenter, and P.-C. Bürkner. 2021. Rank-Normalization, Folding, and Localization: An Improved \hat{R} for Assessing Convergence of MCMC (with Discussion). *Bayesian Analysis* 16:667 – 718.
- Walters, C. 1986. Adaptive Management of Renewable Resources. Macmillian, New York.
- Williams, B. K., and F. A. Johnson. 1995. Adaptive management and the regulation of waterfowl harvests. *Wildlife Society Bulletin* 23:430–436.
- Williams, B. K., F. A. Johnson, and K. Wilkins. 1996. Uncertainty and the adaptive management of waterfowl harvests. *Journal of Wildlife Management* 60:223–232.
- Williams, B. K., J. D. Nichols, and M. J. Conroy. 2002. *Analysis and Management of Animal Populations*. Academic Press, San Diego, CA.
- Zimmerman, G. S., J. R. Sauer, K. Fleming, W. A. Link, and P. R. Garrettson. 2015. Combining waterfowl and breeding bird survey data to estimate wood duck breeding population size in the Atlantic Flyway. *Journal of Wildlife Management* 79:1051–1061.
- Zimmerman, G. S., J. R. Sauer, W. A. Link, and M. Otto. 2012. Composite analysis of black duck breeding population surveys in eastern North America. *Journal of Wildlife Management* 76:1165–1176.
- Zimmerman, G. S., K. D. R. W. A. Link, M. J. Sauer, and G. S. Boomer. 2010. Estimating migratory game-bird productivity by integrating age ratio and banding data. *Wildlife Research* 37:612–6202.

Appendix A 2024-2025 Regulatory Schedule

SCHEDULE^(a) OF BIOLOGICAL INFORMATION AVAILABILITY, REGULATIONS MEETINGS AND FEDERAL REGISTER PUBLICATIONS FOR THE 2025-26 HUNTING SEASON

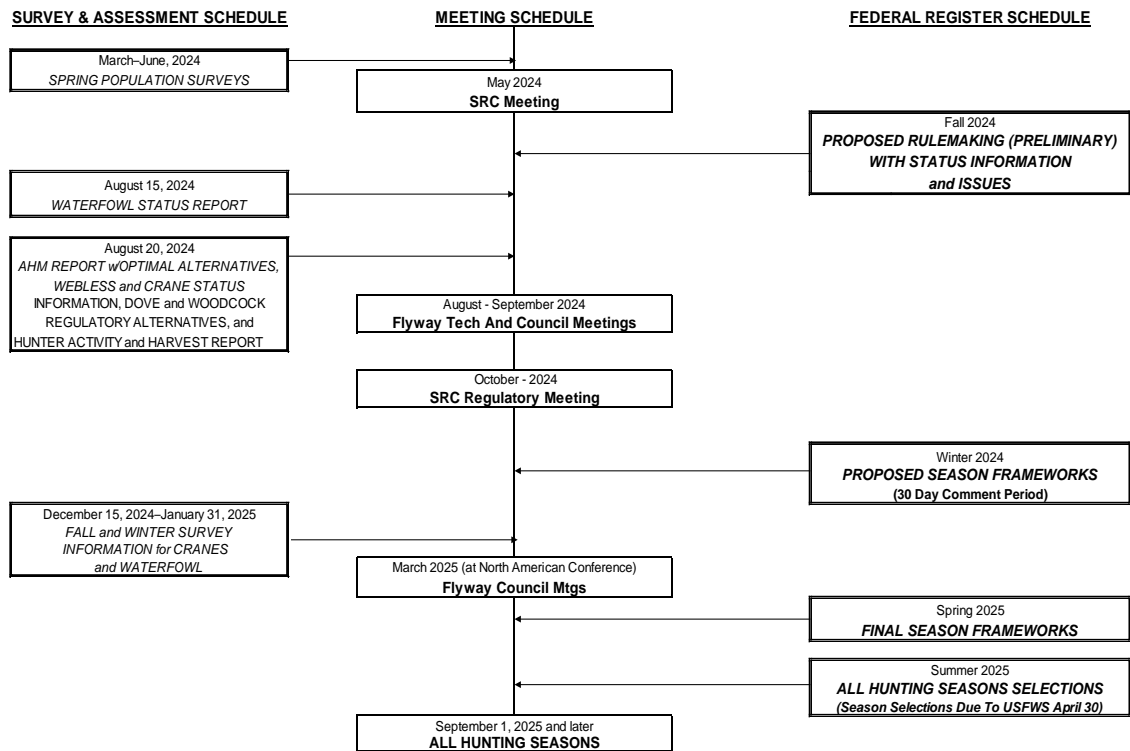

(a) All publication dates of Federal Register documents are target dates.

Figure A.1 – Schedule of biological information availability, regulation meetings, and Federal Register publications for the 2025–2026 hunting season.

Appendix B Harvest Management Working Group Members

The current membership of the Harvest Management Working Group in 2024. Not listed here are numerous persons from federal and state agencies that assist the Working Group on an ad-hoc basis.

Coordinator:

Scott Boomer
U.S. Fish & Wildlife Service
11510 American Holly Drive
Laurel, Maryland 20708-4017
phone: 301-497-5684; fax: 301-497-5871
e-mail: scott.boomer@fws.gov

USFWS Representatives:

Nanette Seto (Region 1)
U.S. Fish & Wildlife Service
911 NE 11TH Avenue
Portland, OR 97232-4181
phone: 503 231-6159
fax: 503 231-2019
e-mail: nanette_seto@fws.gov

Kristin Madden (Region 2)
U.S. Fish & Wildlife Service
500 Gold Ave. SW, Room 8035
Albuquerque, NM 87103-1306
phone: 505-248-6876
fax: 505-248-6460
e-mail: kristin_madden@fws.gov

Brian Smith (Region 3)
U.S. Fish & Wildlife Service
2651 Coolidge Rd. Suite 101
East Lansing, MI 48823
phone: 303-236-4403
fax:
e-mail: brian_w_smith@fws.gov

Bill Uihlein (Region 4)
U.S. Fish & Wildlife Service
1875 Century Blvd.
Atlanta, GA 30345
phone: 404-679-7288
fax: 404 679-4180
e-mail: bill_uihlein@fws.gov

Pam Toschik (Region 5)
U.S. Fish & Wildlife Service
300 Westgate Center Drive
Hadley, MA 01035-9589
phone: 413-253-8610
fax: 413-253-8293
e-mail: pamela_toschik@fws.gov

Orien Richmond (Region 6)
U.S. Fish & Wildlife Service

Denver, CO 80225-0486
phone: 303-501-6042
fax:
e-mail: orien_richmond@fws.gov

Wendy Loya (Region 7)
U.S. Fish & Wildlife Service
1011 East Tudor Road
Anchorage, AK 99503-6119
phone: 907-786-3532

Dan Blake (Region 8)
U.S. Fish & Wildlife Service
2800 Cottage Way, W-2606
Sacramento, CA 95825
phone: 916-414-6477

fax: 907-786-3641
e-mail: wendy_loya@fws.gov

Kathy Fleming (Headquarters)
Chief, Branch of Monitoring and Data Management
U.S. Fish & Wildlife Service
11510 American Holly Drive
Laurel, Maryland 20708-4017
phone: 301-497-5902
fax: 301-497-5871
e-mail: kathy_fleming@fws.gov

Pat Devers (Headquarters)
Atlantic Flyway Representative
U.S. Fish & Wildlife Service
11510 American Holly Drive
Laurel, MD 20708
phone: 571-565-0199
fax: 301-497-5871
e-mail: pat_devers@fws.gov

Tom Cooper (Headquarters)
Central Flyway Representative
U.S. Fish & Wildlife Service
5600 American Blvd West
Bloomington, MN 55437-1458
phone: 612-713-5101
fax: 612-713-5393
e-mail: tom_cooper@fws.gov

Canadian Wildlife Service Representatives:

Christian Roy
Canadian Wildlife Service
351 Saint-Joseph Blvd,
Gatineau, Que, K1A 0H3
phone: 819-938-5418
fax:
e-mail: christian.roy3@canada.ca

Flyway Council Representatives:

Min Huang (Atlantic Flyway)
CT Dept. of Environmental Protection
Franklin Wildlife Mgmt. Area

fax: 916-414-6486
e-mail: daniel.blake@fws.gov

Vacant (Headquarters)
Chief, Branch of Assessment and Decision Support
U.S. Fish & Wildlife Service
11510 American Holly Drive
Laurel, Maryland 20708-4017
phone:
fax: 301-497-5871
e-mail:

Dave Scott (Headquarters)
Mississippi Flyway Representative
U.S. Fish & Wildlife Service
14000 OH-2, Ottawa National Wildlife Refuge
Oak Harbor, OH 43449
phone: 612-597-2131
fax:
e-mail: david.scott@fws.gov

Todd Sanders (Headquarters)
Pacific Flyway Representative
U.S. Fish & Wildlife Service
SE Cardinal Court, Suite 100
Vancouver, WA 98683
phone: 360-604-2562
fax: 360-604-2505
e-mail: todd_sanders@fws.gov

Jim Leafloor
Canadian Wildlife Service
Suite 150, 123 Main Street
Winnipeg, MB R3C 4W2
phone: 204-983-5258
fax:
e-mail: jim.leafloor@canada.ca

Josh Stiller (Atlantic Flyway)
NYS Dept. of Environmental Conservation
625 Broadway

391 Route 32 North Franklin, CT 06254
phone: 860-642-6528
fax: 860-642-7964
e-mail: min.huang@po.state.ct.us

John Brunjes (Mississippi Flyway)
Kentucky Dept. Of Fish and Wildlife Resources
1 Sportsman's Lane
Frankfort, KY 40601
phone: 502-892-4500
fax:
e-mail: john.brunjes@ky.gov

Mike Szymanski (Central Flyway)
North Dakota Game and Fish Department
100 North Bismarck Expressway
Bismarck, ND 58501-5095
phone: 701-328-6360
fax: 701-328-6352
e-mail: mszymanski@state.nd.us

Brandon Reishus (Pacific Flyway)
Oregon Dept of Fish and Wildlife
4034 Fairview Industrial Dr. SE
Salem, OR 97302
phone: 503-947-6324
fax: 503-947-6330
e-mail: brandon.s.reishus@state.or.us

USGS Scientist:

Mike Runge (USGS)
Patuxent Wildlife Research Center
U.S. Geological Survey
12100 Beech Forest Rd. Laurel, MD 20708
phone: 301-497-5748
fax: 301-497-5545
e-mail: mrunge@usgs.gov

Albany, N.Y. 12233
phone: 518-402-8861
fax: 518-402-8925
e-mail: Joshua.stiller@dec.ny.gov

Adam Phelps (Mississippi Flyway)
Indiana Division of Fish and Wildlife
5596 E State Road 46
Bloomington, IN 47401
phone: 812-334-1137
fax: 812-339-4807
e-mail: APhelps@dnr.IN.gov

Kevin Kraai (Central Flyway)
Texas Parks and Wildlife Department
P.O. Box 659
Canyon, TX 79015
phone: 806-651-3011
fax:
email: kevin.kraai@tpwd.texas.gov

Jason Schamber (Pacific Flyway)
Alaska Dept. Fish & Game
525 W. 67th Ave
Anchorage, AK 99518
phone: 907-267-2206
fax: 907-267-2859
e-mail: jason.schamber@alaska.gov

Appendix C

Harvest Management Working Group Priorities

Table C.1 – Priority rankings and project leads identified for the technical work proposed at the 2023 Harvest Management Working Group meeting and updated during the summer of 2024.

Priority Level	Status	Participants
Highest Priorities (Urgent and Important)		
Reconsideration of North American duck harvest management	On-going	Flyway Councils, DMBM
Evaluation of the implications of changes in monitoring frequency on adaptive harvest management performance	On-going	Flyway Councils, DMBM, USGS
Evaluation of experimental two-tier license system	On-going	Central Flyway, DMBM
Scaup AHM revision/assessment of diving duck harvest capacity	Proposed	Flyway Councils, DMBM
Long-range Priorities (Non-urgent, but Very Important)		
Time-dependent optimal solutions to address system change (e.g., habitat change; hunter dynamics; climate change).	On-going	USGS, BADS
Additional Priorities		
Northern Pintail AHM strategy evaluation	On-going	Flyway Councils, DMBM, USGS
Western mallard AHM revision	On-going	Pacific Flyway, BADS

Appendix D Mid-Continent Mallard Models

In 1995, we developed population models to predict changes in mid-continent mallards based on the traditional survey area which includes individuals from Alaska (Johnson et al. 1997). In 1997, we added mallards from the Great Lakes region (Michigan, Minnesota, and Wisconsin) to the mid-continent mallard stock, assuming their population dynamics were equivalent. In 2002, we made extensive revisions to the set of alternative models describing the population dynamics of mid-continent mallards (Runge et al. 2002, U.S. Fish and Wildlife Service 2002). In 2008, we redefined the population of mid-continent mallards (Table D.1) to account for the removal of Alaskan birds (WBPHS strata 1–12) that are now considered to be in the western mallard stock and have subsequently rescaled the model set accordingly. In 2022, we implemented an integrated population model (Besbeas et al. 2002, Arnold et al. 2018) to estimate mid-continent mallard population parameters as a basis for deriving an optimal strategy. With this approach, we can update demographic parameter estimates each year as a function of the most recent monitoring information, including breeding population estimates, band-recovery, and age ratio information. We then account for the uncertainty in key population parameters in the optimization as these parameters change over time.

Model Structure

Collectively, the models express uncertainty (or disagreement) about whether harvest is an additive or compensatory form of mortality (Burnham et al. 1984), and whether the reproductive process is weakly or strongly density-dependent (i.e., the degree to which reproductive rates decline with increasing population size).

The mid-continent mallard population model can be expressed as a “balance equation” to predict changes in breeding-population size as a function of annual survival and reproductive rates:

$$N_{t+1} = N_t (mS_{t,AM} + (1 - m)(S_{t,AF} + R_t(S_{t,JF}/SS_f + S_{t,JM}/SS_m)))$$

where:

N =breeding population size,

m = proportion of males in the breeding population,

S_{AM} , S_{AF} , S_{JF} , and S_{JM} = survival rates of adult males, adult females, young females, and young males, respectively,

R = reproductive rate, defined as the fall age ratio of females,

SS_m and SS_f = breeding season survival for adult male and females respectively, and t = year.

Survival Process

We considered a single functional form to represent the relationship between annual survival and kill rates. For each cohort, we estimated kill rates, survival in the absence of harvest, and a sex specific additivity term with

$$K_{t,sex,age} = h_{t,sex,age}/(1 - c)$$
$$S_{t,sex,age} = S_{0,sex,age} - \alpha_{1,sex}K_{t,sex,age}$$

where s_0 = survival in the absence of harvest, α_1 is an additivity parameter, and K = harvest rate (h) adjusted for crippling loss ($c = 20\%$, Anderson and Burnham 1976). This parameterization allows us to admit a range of relationships, including partial compensation, between harvest mortality and annual survival that is informed by the data with each year’s update of band-recovery information. As these parameter values change over time, we can continue to learn how each cohort’s survival rates are responding to annual harvest rates. The 2024 posterior estimates of model parameters based on data from 1974 to 2024 are provided in Table D.2.

Table D.1 – Estimates (N) and associated standard errors (SE) of mid-continent mallards (in millions) observed in the WBPMS (strata 13–18, 20–50, and 75–77) and the Great Lakes region (Michigan, Minnesota, and Wisconsin) from 1992–2024. The 2020–21 numbers are model predictions based on the most recent information.

Year	WBPMS area		Great Lakes region		Total	
	N	SE	N	SE	N	SE
1992	5.6304	0.2379	0.9964	0.0969	6.6267	0.2569
1993	5.4253	0.2068	0.9176	0.0644	6.3429	0.2166
1994	6.6292	0.2803	1.1304	0.0991	7.7596	0.2973
1995	7.7452	0.2793	1.0857	0.1005	8.8309	0.2968
1996	7.4193	0.2593	1.0074	0.0841	8.4267	0.2726
1997	9.3554	0.3041	1.0777	0.0949	10.4332	0.3186
1998	8.8041	0.2940	1.0783	0.0956	9.8825	0.3091
1999	10.0926	0.3374	1.0309	0.1022	11.1236	0.3526
2000	8.6999	0.2855	1.1993	0.0978	9.8992	0.3018
2001	7.1857	0.2204	0.8282	0.0605	8.0139	0.2285
2002	6.8364	0.2412	1.0684	0.0782	7.9047	0.2536
2003	7.1062	0.2589	0.8407	0.0562	7.9470	0.2649
2004	6.6142	0.2746	0.9465	0.0791	7.5607	0.2858
2005	6.0521	0.2754	0.8138	0.0603	6.8660	0.2820
2006	6.7607	0.2187	0.6249	0.0491	7.3856	0.2241
2007	7.7258	0.2805	0.7904	0.0611	8.5162	0.2870
2008	7.1914	0.2525	0.6865	0.0487	7.8779	0.2571
2009	8.0094	0.2442	0.6958	0.0563	8.7052	0.2506
2010	7.8246	0.2799	0.7808	0.0586	8.6054	0.2860
2011	8.7668	0.2650	0.7306	0.0642	9.4974	0.2726
2012	10.0959	0.3199	0.8612	0.1751	10.9571	0.3647
2013	10.0335	0.3586	0.7638	0.0744	10.7973	0.3662
2014	10.3989	0.3429	0.6459	0.0681	11.0448	0.3496
2015	11.1724	0.3582	0.6202	0.0514	11.7926	0.3619
2016	11.2083	0.3615	0.6925	0.0707	11.9008	0.3684
2017	9.9500	0.3298	0.6927	0.0523	10.6427	0.3339
2018	8.8044	0.2955	0.7634	0.0702	9.5678	0.3037
2019	9.0624	0.2823	0.6698	0.0679	9.7322	0.2903
2020	8.5169	0.7668	0.6767	0.0791	9.1936	0.7708
2021	7.9958	0.7368	0.7327	0.0934	8.7285	0.7427
2022	6.8198	0.2330	0.5554	0.0468	7.3752	0.2377
2023	5.7448	0.2018	0.4716	0.0547	6.2164	0.2091
2024	6.1027	0.2472	0.5093	0.0518	6.6119	0.2525

Table D.2 – Survival parameter estimates (logit scale) resulting from the mid-continent mallard IPM.

Parameter	Mean	SD	2.5% CI	Median	97.5% CI
S_{0AM}	1.1763	0.0179	1.1425	1.1759	1.2123
S_{0AF}	0.5051	0.0201	0.4653	0.5050	0.5436
S_{0JM}	1.3420	0.0370	1.2724	1.3414	1.4151
S_{0JF}	0.7043	0.0525	0.6015	0.7048	0.8055
α_{1f}	1.3287	0.2729	0.7952	1.3272	1.8508
α_{1m}	2.6439	0.1433	2.3755	2.6404	2.9293

Reproductive Process

Annual reproductive rates were estimated from age ratios in the harvest of females, corrected using annual estimates of differential vulnerability calculated within the IPM. Predictor variables were the number of total ponds observed in Prairie Canada and the U.S. (P , in millions) and the size of the true, latent breeding population predicted by the IPM (N , in millions). We used the parameterization developed by [Zimmerman et al. \(2010\)](#) to integrate the age ratio and vulnerability information while accounting for the necessary forms of uncertainty within the IPM. The linear sub-model used to predict recruitment as a function of covariates was:

$$R_t = -0.5591 + 0.1230P_t - 0.0501N_t$$

Pond Dynamics

We modeled annual variation in total ponds (US and Canadian ponds observed in WBPBS strata 26–49) as a first-order autoregressive process. The estimated model was:

$$P_{t+1} = 5.0571 + 0.4757(P_t - 5.0571) + \varepsilon_t$$

where ponds are in millions and ε_t is normally distributed with mean = 0 and variance = 1.3048².

State-Space Estimation

We used a Bayesian, state-space modeling framework to estimate mid-continent mallard demographic parameters and true, latent population states (BPOP and total ponds). Using the balance equation and sub-models described above, predictions of the breeding-population size in year $t+1$ depend only on the true, latent population size, pond numbers, and harvest rates in year t . For the period in which comparisons were possible, we related each year's prediction to the true, unobserved population size with:

$$N_t^{true} \sim \text{Lognormal} \left(N_t^{pred}, \sigma_{process}^2 \right)$$

where $\sigma_{process}^2$ is estimated within the IPM. The 2024 estimate of the process error is equal to 0.0944².

For the period in which comparisons were possible, we related each year's observed breeding population estimates from the WBPBS to the true, unobserved population sizes with:

$$N_t^{obs} \sim \text{Normal} \left(N_t^{true}, \sigma_{obs,t}^2 \right)$$

where $\sigma_{obs,t}^2$ are assumed known and estimated each year from the WBPBS observations.

Parametric Uncertainty

We accounted for the uncertainty in the strength of density dependence in the recruitment relationship and the degree of additivity in the survival sub-models by representing these key parameters as random variables in the optimization procedures used to derive mid-continent mallard harvest policies. This process becomes adaptive as the parameter values evolve in response to our decision making and environmental changes and these updated values are formally incorporated into the optimization used to inform the next regulatory decision (Walters 1986). Moreover, we expect that the consistent updating of these relationships with new observations from our annual monitoring programs will enable us to track population-level responses to large-scale system changes affecting adaptive harvest management performance.

Appendix E Western Mallard Models

In contrast to the mid-continent mallard AHM framework, we did not model changes in population size for both the Alaska and southern Pacific Flyway (California, Oregon, Washington, and British Columbia combined) substocks of western mallards (Table E.1) as an explicit function of survival and reproductive rate estimates (which in turn may be functions of harvest and environmental covariates). We believed this so-called “balance-equation approach” was not viable for western mallards because of insufficient banding in Alaska to estimate survival rates, and because of the difficulty in estimating substock-specific fall age ratios from a sample of wings derived from a mix of breeding stocks.

Table E.1 – Estimates (N) and associated standard errors (SE) of western mallards (in millions) observed in Alaska (WBPBS strata 1–12) and the southern Pacific Flyway (California, Oregon, Washington, and British Columbia combined) from 1990–2024. The waterfowl breeding population surveys were not conducted in 2020 due to the COVID-19 pandemic; 2020 numbers are based on model predictions. Surveys in the southern Pacific Flyway and strata 12 in Alaska were not surveyed in 2021 because of the pandemic; data for Alaska strata 12 were imputed and 2021 numbers for the southern Pacific Flyway are based on model predictions.

Year	Alaska		CA-OR ^a		WA-BC		SO-PF ^b Total		Total	
	N	SE	N	SE	N	SE	N	SE	N	SE
1990	0.3669	0.0370	NA	NA	NA	NA	NA	NA	NA	NA
1991	0.3853	0.0363	NA	NA	NA	NA	NA	NA	NA	NA
1992	0.3457	0.0387	NA	NA	NA	NA	NA	NA	NA	NA
1993	0.2830	0.0295	NA	NA	NA	NA	NA	NA	NA	NA
1994	0.3509	0.0371	0.4281	0.0425	NA	NA	NA	NA	NA	NA
1995	0.5242	0.0680	0.4460	0.0427	NA	NA	NA	NA	NA	NA
1996	0.5220	0.0436	0.6389	0.0802	NA	NA	NA	NA	NA	NA
1997	0.5842	0.0520	0.6325	0.1043	NA	NA	NA	NA	NA	NA
1998	0.8362	0.0673	0.4788	0.0489	NA	NA	NA	NA	NA	NA
1999	0.7131	0.0696	0.6857	0.1066	NA	NA	NA	NA	NA	NA
2000	0.7703	0.0522	0.4584	0.0532	NA	NA	NA	NA	NA	NA
2001	0.7183	0.0541	NA	NA	NA	NA	NA	NA	NA	NA
2002	0.6673	0.0507	0.3698	0.0327	NA	NA	NA	NA	NA	NA
2003	0.8435	0.0668	0.4261	0.0501	NA	NA	NA	NA	NA	NA
2004	0.8111	0.0639	0.3449	0.0352	NA	NA	NA	NA	NA	NA
2005	0.7031	0.0547	0.3920	0.0474	NA	NA	NA	NA	NA	NA
2006	0.5158	0.0469	0.4805	0.0576	NA	NA	NA	NA	NA	NA
2007	0.5815	0.0551	0.4808	0.0546	NA	NA	NA	NA	NA	NA
2008	0.5324	0.0468	0.3725	0.0478	NA	NA	NA	NA	NA	NA
2009	0.5030	0.0449	0.3746	0.0639	NA	NA	NA	NA	NA	NA
2010	0.6056	0.0531	0.4347	0.0557	0.1740	0.0132	0.6087	0.0572	1.2143	0.0781
2011	0.4158	0.0388	0.3763	0.0452	0.1411	0.0117	0.5174	0.0467	0.9332	0.0607
2012	0.5056	0.0511	0.4759	0.0550	0.1650	0.0117	0.6409	0.0563	1.1465	0.0760
2013	0.3384	0.0382	0.3830	0.0527	0.1573	0.0117	0.5403	0.0540	0.8787	0.0661
2014	0.5009	0.0574	0.3239	0.0553	0.1690	0.0123	0.4929	0.0566	0.9938	0.0806
2015	0.4709	0.0509	0.2612	0.0295	0.1678	0.0114	0.4290	0.0316	0.8999	0.0599
2016	0.5842	0.0654	0.3511	0.0365	0.1339	0.0078	0.4850	0.0373	1.0692	0.0753
2017	0.5385	0.0519	0.2701	0.0324	0.1743	0.0120	0.4444	0.0346	0.9828	0.0624
2018	0.4508	0.0451	0.3700	0.0436	0.2042	0.0115	0.5743	0.0451	1.0250	0.0637
2019	0.3611	0.0353	0.3237	0.0330	0.2008	0.0142	0.5245	0.0359	0.8855	0.0504
2020	0.4951	0.0842	NA	NA	NA	NA	0.4991	0.0640	0.9942	0.1058
2021	0.6440	0.0591	NA	NA	NA	NA	0.4692	0.0595	1.1132	0.0839
2022	0.6144	0.0698	0.2588	0.0305	0.1683	0.0095	0.4270	0.0320	1.0415	0.0768
2023	0.3809	0.0421	0.2707	0.0294	0.1728	0.0122	0.4435	0.0318	0.8244	0.0528
2024	0.5066	0.0575	0.2489	0.0227	0.1830	0.0122	0.4319	0.0257	0.9385	0.0630

^a Available California survey estimates begin in 1992; Oregon surveys estimates begin in 1994 and were unavailable in 2001.

^b Southern Pacific Flyway includes California, Oregon, Washington, and British Columbia observations.

Model Structure

To evaluate western mallard population dynamics, we used a discrete logistic model (Schaefer 1954), which combines reproduction and natural mortality into a single parameter r , the intrinsic rate of growth. The model assumes density-dependent growth, which is regulated by the ratio of population size, N , to the carrying capacity of the environment, K (i.e., equilibrium population size in the absence of harvest). In the traditional formulation, harvest mortality is additive to other sources of mortality, but compensation for hunting losses can occur through subsequent increases in production. However, we parameterized the model in a way that also allows for compensation of harvest mortality between the hunting and breeding seasons. It is important to note that compensation modeled in this way is purely phenomenological, in the sense that there is no explicit ecological mechanism for compensation (e.g., density-dependent mortality after the hunting season). The basic model for both the Alaska and southern Pacific Flyway substocks has the form:

$$N_{t+1} = \left[N_t + N_t r \left(1 - \frac{N_t}{K} \right) \right] (1 - \alpha_t)$$

where,

$$\alpha_t = dh_t^{AM}$$

and where t = year, h^{AM} = the harvest rate of adult males, and d = a scaling factor. The scaling factor is used to account for a combination of unobservable effects, including un-retrieved harvest (i.e., crippling loss), differential harvest mortality of cohorts other than adult males, and for the possibility that some harvest mortality may not affect subsequent breeding-population size (i.e., the compensatory mortality hypothesis).

Estimation Framework

We used Bayesian estimation methods in combination with a state-space model that accounts explicitly for both process and observation error in breeding population size. This combination of methods is widely used in natural resource modeling, in part because it facilitates the fitting of non-linear models that may have non-normal errors (Meyer and Millar 1999). The Bayesian approach also provides a natural and intuitive way to portray uncertainty, allows one to incorporate prior information about model parameters, and permits the updating of parameter estimates as further information becomes available. Breeding population data are available for California and Oregon from 1994–2019 (except for 2001) and 2022–2024, British Columbia from 2006–2019 and 2022–2024, and Washington from 2010–2019 and 2022–2024 (see Table E.1). We attempted to use correlations with adjacent states to impute data back to 1992 for Washington and British Columbia, but could not find a reasonable correlation between those surveys and other regions (potentially due to a short time series). Therefore, we imputed population estimates for British Columbia, and Washington by sampling values from the mean and variance within the MCMC framework. Specifically, we calculated the total mean and variance of breeding population sizes based on observed data (2006–2019 and 2022–2024 for British Columbia, and 2010–2019 and 2022–2024 for Washington), and then used those means and variances to sample a population size for the missing years (1992–2005 for British Columbia; and 1992–2009 for Washington) during each iteration of MCMC sampling. Although this approach imputes values based on a random draw, it does acknowledge added uncertainty in those estimates compared to the years with observed data. Further, given the low annual variability and lack of trend, we have no evidence that the recent survey estimates used to generate the mean and variance are not a reasonable approximation of historical breeding population sizes.

We first scaled N by K as recommended by Meyer and Millar (1999), and assumed that process errors were lognormally distributed with mean 0 and variance σ^2 . Thus, the process model had the form:

$$\begin{aligned} P_t &= N_t/K \\ \log(P_t) &= \log \left([P_{t-1} + P_{t-1}r(1 - P_{t-1})] (1 - dh_{t-1}^{AM}) \right) + e_t \end{aligned}$$

where,

$$e_t \sim \text{Normal}(0, \sigma^2)$$

The observation model related the unknown population sizes ($P_t K$) to the population sizes (N_t) estimated from the breeding-population surveys in Alaska and southern Pacific Flyway. We assumed that the observation process yielded additive, normally distributed errors, which were represented by:

$$N_t = P_t K + \varepsilon_t^{BPOP},$$

where,

$$\varepsilon_t^{BPOP} \sim \text{Normal}(0, \sigma_{BPOP}^2).$$

permitting us to estimate the process error, which reflects the inability of the model to completely describe changes in population size. The process error reflects the combined effect of misspecification of an appropriate model form, as well as any un-modeled environmental drivers. We initially examined a number of possible environmental covariates, including the Palmer Drought Index in California and Oregon, spring temperature in Alaska, and the El Niño Southern Oscillation Index (<http://www.cdc.noaa.gov/people/klaus.wolter/MEI/mei.html>). While the estimated effects of these covariates on r or K were generally what one would expect, they were never of sufficient magnitude to have a meaningful effect on optimal harvest strategies. We therefore chose not to further pursue an investigation of environmental covariates, and posited that the process error was a sufficient surrogate for these un-modeled effects. Parameterization of the models also required measures of harvest rate. Prior to 1993, we used direct recoveries of standard bands, corrected for band-reporting rates provided by [Nichols et al. \(1995b\)](#). We also used the band-reporting rates provided by [Nichols et al. \(1995b\)](#) for estimating harvest rates in 1994 and 1995, except that we inflated the reporting rates of full-address and toll-free bands based on an unpublished analysis by Clint Moore and Jim Nichols (Patuxent Wildlife Research Center). We were unwilling to estimate harvest rates for the years 1996–2001 because of suspected, but unknown, increases in the reporting rates of all bands. Beginning in 2002 we used toll free and web address bands, and the reporting rate estimates for the Pacific Flyway provided by [Boomer et al. \(2013\)](#). For simplicity, harvest rate estimates were treated as known values in our analysis, although future analyses might benefit from an appropriate observation model for these data.

The state-space model is informed by the population sizes estimated from breeding-population surveys. However, the southern Pacific flyway was not surveyed in 2020 and 2021, and Alaska was not surveyed in 2020 because of the COVID-19 pandemic. For these years with missing data, we predicted population size from the process model. We included process error from the state-space model and predicted sampling error associated with breeding-population survey in the prediction variance.

We predicted sampling variance using the mean CV from years when we had observed data. First, we used simple linear regression to determine the correlation between breeding-population size estimates on their standard errors in Alaska (1990–2019, 2021–2024) and the southern Pacific Flyway (2010–2019, 2022–2024) separately. Output from the linear model was treated as data in the state-space model, including: degrees of freedom (Alaska $df = 33$; southern Pacific Flyway [sPF] $df = 12$), residual standard error (Alaska $RSE = 0.008$; sPF $RSE = 0.007$), the coefficient of the relationship of population size estimates and standard error of estimates, which represents an estimate of the mean CV, (Alaska $\beta = 0.091$; sPF $\beta = 0.084$), and the standard error of the coefficient (Alaska $\sigma_\beta = 0.003$; sPF $\sigma_\beta = 0.004$). For years with no observed breeding population, we assumed the latent population size N_t was a normally distributed random parameter with an expected mean $P_t K$ and standard deviation v :

$$N_t \sim N(P_t K, v_t^2)$$

where,

$$v_t \sim N(P_t K \alpha, \kappa)$$

where α is a sampled CV from the parameters of the linear regression:

$$\alpha \sim N(\beta, \sigma_\beta)$$

and κ represents the standard error of this relationship, which is informed by df and RSE from the linear regression. The parameter κ can be interpreted as our confidence in predictions of abundance when no surveys were completed, which increases as more years of observations are used to inform the linear regression.

In a Bayesian analysis, one is interested in making probabilistic statements about the model parameters (θ), conditioned on the observed data. Thus, we are interested in evaluating $P(\theta|data)$, which requires the specification of prior distributions for all model parameters and unobserved system states (θ) and the sampling distribution (likelihood) of the observed data $P(data|\theta)$. Using Bayes theorem, we can represent the posterior probability distribution of model parameters, conditioned on the data, as:

$$P(\theta|data) \propto P(\theta) \times P(data|\theta)$$

Accordingly, we specified prior distributions for model parameters r , K , d , and P_0 , which is the initial population size relative to carrying capacity. For both substocks, we specified the following prior distributions for r , d , and σ^2 :

$$r \sim \text{Lognormal}(-1.0397, 0.69315)$$

$$d \sim \text{Uniform}(0, 2)$$

$$\sigma^2 \sim \text{Inverse-gamma}(0.001, 0.001)$$

The prior distribution for r is centered at 0.35, which we believe to be a reasonable value for mallards based on life-history characteristics and estimates for other avian species. Yet the distribution also admits considerable uncertainty as to the value of r within what we believe to be realistic biological bounds. As for the harvest-rate scalar, we would expect $d \geq 1$ under the additive hypothesis and $d < 1$ under the compensatory hypothesis. As we had no data to specify an informative prior distribution, we specified a vague prior in which d could take on a wide range of values with equal probability. We used a traditional, uninformative prior distribution for σ^2 . Prior distributions for K and P_0 were substock-specific and are described in the following sections.

We used the public-domain software JAGS (Plummer 2003; <https://sourceforge.net/projects/mcmc-jags>) to derive samples from the joint posterior distribution of model parameters via MCMC simulations. We specified 20,000 adaptive iterations for each chain and obtained 500,000 samples from the joint posterior distribution, discarding the first 400,000 to ensure there was no influence of starting values. We thinned the remaining iterations by 50 which resulted in a sample of 2,000 for each of the 5 chains, or 10,000 total samples.

Alaska mallards

Data selection—Breeding population estimates of mallards in Alaska (and the Old Crow Flats in Yukon) are available since 1955 in WBPHS strata 1–12 (Smith 1995). However, a change in survey aircraft in 1977 instantaneously increased the detectability of waterfowl, and thus population estimates (Hodges et al. 1996). Moreover, there was a rapid increase in average annual temperature in Alaska at the same time, apparently tied to changes in the frequency and intensity of El Niño events (<http://www.cdc.noaa.gov/people/klaus.wolter/MEI/mei.html>). This confounding of changes in climate and survey methods led us to truncate the years 1955–1977 from the time series of population estimates.

Modeling of the Alaska substock also depended on the availability of harvest-rate estimates derived from band-recovery data. Unfortunately, sufficient numbers of mallards were not banded in Alaska prior to 1990. A search for covariates that would have allowed us to make harvest-rate predictions for years in which band-recovery data were not available was not fruitful, and we were thus forced to further restrict the time series to 1990 and later. Even so, harvest rate estimates were not available for the years 1996–2001, and 2014 because of unknown changes in band-reporting rates or lack of banding data. Because available estimates of harvest rate showed no apparent variation over time, we simply used the mean and standard deviation of the available estimates and generated independent samples of predictions for the missing years based on a logit transformation and an assumption of normality:

$$\ln\left(\frac{h_t}{1-h_t}\right) \sim \text{Normal}(-2.3763, 0.0709) \quad \text{for } t = 1996\text{--}2001, \text{ and } 2014.$$

Prior distributions for K and P_0 —We believed that sufficient information was available to use mildly informative priors for K and P_0 . During the development of this framework, the Alaska substock had approximately 0.8 million mallards. If harvest rates have been comparable to that necessary to achieve maximum sustained yield (MSY) under the logistic model (i.e., $r/2$), then we would expect $K \approx 1.6$ million. On the other hand, if harvest rates have been less than those associated with MSY, then we would expect $K < 1.6$ million. Because we believed it was not likely that harvest rates were $> r/2$, we believed the likely range of K to be 0.8–1.6 million. We therefore specified a prior distribution that had a mean of 1.14 million, but had a sufficiently large variance to admit a wide range of possible values:

$$K \sim \text{Lognormal}(0.13035, 0.41224)$$

Extending this line of reasoning, we specified a prior distribution that assumed the estimated population size of approximately 0.4 million at the start of the time series (i.e., 1990) was 20–60% of K . Thus on a log scale:

$$P_0 \sim \text{Uniform}(-1.6094, -0.5108)$$

Parameter estimates—The logistic model and associated posterior parameter estimates provided a reasonable fit to the observed time series of population estimates. The posterior means of K and r were similar to their priors, although their variances were considerably smaller (Table E.2). However, the posterior distribution of d was essentially the same as its prior, reflecting the absence of information in the data necessary to reliably estimate this parameter.

Table E.2 – Estimates of model parameters resulting from fitting a discrete logistic model to a time series of estimated population sizes and harvest rates of mallards breeding in Alaska from 1990–2024.

Parameter	Mean	SD	2.5% CI ^a	Median	97.5% CI
K	1.015	0.288	0.625	0.950	1.741
d	1.235	0.492	0.195	1.295	1.966
r	0.323	0.129	0.103	0.311	0.606
σ^2	0.029	0.011	0.013	0.027	0.057

^a CI = credible interval.

Southern Pacific Flyway (CA-OR-WA-BC) mallards

Data selection—Breeding-population estimates of mallards in California are available starting in 1992, but not until 1994 in Oregon. Also, Oregon did not conduct a survey in 2001. To avoid truncating the time series, we used the relationship ($P = 0.01$) between California–Oregon population estimates to predict population sizes in Oregon in 1992, 1993, and 2001. The fitted linear model was:

$$N_t^{OR} = 58264 + 0.0960(N_t^{CA})$$

To derive realistic standard errors, we assumed that the predictions had the same mean coefficient of variation as the years when surveys were conducted ($n = 28$, $CV = 0.091$). The estimated sizes and variances of the southern Pacific Flyway substock were calculated by simply summing the state-specific estimates.

We pooled band-recovery data for the southern Pacific Flyway substock and estimated harvest rates in the same manner as that for Alaska mallards. Although banded sample sizes were sufficient in all years, harvest rates could not be estimated for the years 1996–2001 because of unknown changes in band-reporting rates. As with Alaska, available estimates of harvest rate showed no apparent trend over time, and we simply used the mean and standard deviation of the available estimates and generated independent samples of predictions for the missing years based on a logit transformation and an assumption of normality:

$$\ln\left(\frac{h_t}{1-h_t}\right) \sim \text{Normal}(-1.8200, 0.0324) \quad \text{for } t = 1996\text{--}2001$$

Prior distributions for K and P_0 —Unlike the Alaska substock, the California-Oregon population had been relatively stable with a mean of 0.48 million mallards while developing western mallard AHM. We believed K should be in the range 0.48–0.96 million, assuming the logistic model and that harvest rates were $\leq r/2$. The addition of Washington and British Columbia mallards to the southern Pacific Flyway substock did not result in substantive changes to historically stable population dynamics, but increased the overall size of the southern Pacific Flyway population by approximately 30%. Therefore, we scaled the prior to increase the expected carrying capacity by 30%. We specified a prior distribution on K that had a mean of 0.8 million, but with a variance sufficiently large to admit a wide range of possible values:

$$K \sim \text{Lognormal}(-0.2262, 0.2638)$$

The estimated size of the California-Oregon substock was 0.47 million at the start of the time series (i.e., California plus the imputed Oregon estimate in 1992). We used a similar line of reasoning as that for Alaska for specifying a prior distribution P_0 , positing that initial population size was 40–100% of K . Thus on a log scale:

$$P_0 \sim \text{Uniform}(-0.9163, 0.0)$$

Parameter estimates—The logistic model and associated posterior parameter estimates provided a reasonable fit to the observed time series of population estimates. The posterior mean of K was slightly greater than its prior and its posterior variance was slightly smaller than its prior (Table E.3). The posterior mean of r was less than its prior and had considerably less variance. Interestingly, the posterior mean of d was < 1 , suggestive of a compensatory response to harvest; however the standard deviation of the estimate was large, with the upper 95% credibility limit > 1 .

Table E.3 – Estimates of model parameters resulting from fitting a discrete logistic model to a time series of estimated population sizes and harvest rates of mallards breeding in the southern Pacific Flyway (California, Oregon, Washington, and British Columbia combined) from 1992–2024.

Parameter	Mean	SD	2.5% CI ^a	Median	97.5% CI
K	0.892	0.211	0.609	0.846	1.417
d	0.637	0.368	0.098	0.573	1.525
r	0.277	0.164	0.064	0.243	0.698
σ^2	0.009	0.005	0.002	0.008	0.023

^a CI = credible interval.

For each western mallard substock, we further summarized the simulation results for r , K , and the scaling factor d to admit parametric uncertainty with a formal correlation structure within the optimization procedure used to

calculate the harvest strategy. We first defined a joint distribution for 3 discrete outcomes for each of the 3 population parameters. We used the 30 and 70 percent quantiles for each parameter as the cut points to define three bins for which to discretize 3 values of each posterior distribution. We then determined the frequency of occurrence of each of the 27 possible combinations of each parameter value falling within the 3 bins from the MCMC simulation results. These frequencies were then assigned parameter values based on the midpoint of bin ranges (15, 50, 85 percent quantiles) to specify the joint distribution of the population parameter values used in the optimization.

Appendix F Atlantic Flyway Multi-Stock Models

Similar to western mallards we did not have adequate data to model changes in breeding population size of the species included in the multi-stock framework (Table F.1) to use the balance-equation approach. Therefore, we used discrete logistic models similar to those used to model western mallard population dynamics. We initially intended to use the same model structure for all four species in the strategy, but because of the lack of preseason banding data for ring-necked ducks and goldeneyes, we implemented two different forms of the discrete logistic model.

Table F.1 – Estimates (N in millions) and associated standard errors (SE) of American green-winged teal (AGWT), wood ducks (WODU), ring-necked ducks (RNDU), and goldeneyes (GOLD) observed in eastern Canada (WBPHS strata 51–53, 56, 62–72) and the U.S. (Atlantic Flyway states) from 1998 to 2024. The waterfowl breeding population surveys were not conducted in 2020 for any species or in 2021 for any species but WODU, due to the COVID-19 pandemic; numbers from years without surveys are based on model predictions.

Year	AGWT ^a		WODU ^b		RNDU ^a		GOLD ^a	
	N	SE	N	SE	N	SE	N	SE
1998	0.2924	0.0681	0.9414	0.1171	0.6064	0.1240	0.6558	0.2052
1999	0.3776	0.0731	0.9496	0.1189	0.7273	0.1546	0.7462	0.1940
2000	0.3469	0.0611	0.8995	0.1104	0.9545	0.3484	0.7097	0.2090
2001	0.2919	0.0556	0.8934	0.1101	0.6895	0.1281	0.8531	0.2600
2002	0.3948	0.0701	0.9258	0.1156	0.7106	0.1185	0.9375	0.2983
2003	0.3827	0.0799	0.8829	0.1086	0.7029	0.1046	0.7257	0.2427
2004	0.4494	0.0915	0.8938	0.1188	0.7774	0.1496	0.6873	0.1836
2005	0.3321	0.0704	0.8753	0.1078	0.6507	0.0951	0.5940	0.1486
2006	0.3224	0.0665	0.9114	0.1133	0.6767	0.1066	0.5271	0.1356
2007	0.4301	0.1269	0.9084	0.1123	0.8777	0.1289	0.7350	0.1938
2008	0.3977	0.0866	0.8660	0.1112	0.6910	0.1254	0.7155	0.1846
2009	0.4177	0.0985	0.8919	0.1120	0.7147	0.1347	0.6121	0.1784
2010	0.4041	0.1023	0.8751	0.1079	0.7019	0.1179	0.6332	0.1845
2011	0.3910	0.1024	0.8790	0.1103	0.6259	0.0985	0.6014	0.1737
2012	0.3549	0.0819	0.9168	0.1153	0.6488	0.1166	0.6372	0.2187
2013	0.3933	0.1698	0.9187	0.1172	0.7859	0.4005	0.7185	NA ^c
2014	0.2990	0.0692	0.9253	0.1138	0.6157	0.1027	0.6173	0.2420
2015	0.3079	0.0717	0.9026	0.1136	0.7278	0.1865	0.4750	0.1382
2016	0.3163	0.0766	0.9123	0.1153	0.7495	0.1411	0.5657	0.1944
2017	0.3361	0.0664	0.9407	0.1448	0.6206	0.1282	0.6499	0.2047
2018	0.3301	0.0706	0.8850	0.1132	0.6436	0.1272	0.5252	0.1604
2019	0.3007	0.0680	0.9268	0.1142	0.7231	0.2094	0.5046	0.2223
2020	0.3613	0.0967	0.9408	0.1309	0.7058	0.1777	0.6535	0.2317
2021	0.3619	0.0968	0.9278	0.1263	0.7101	0.1787	0.6758	0.2401
2022	0.3313	0.0698	0.9147	0.1160	0.6901	0.1122	0.6589	0.1707
2023	0.3843	0.1203	0.9401	0.1217	0.6657	0.1308	0.8365	0.2139
2024	0.4681	0.0999	0.8707	0.1157	0.7310	0.1180	1.2009	0.3207

^a Breeding population size estimates from eastern survey area (WBPHS strata 51–53, 56, 62–72)

^b Breeding population size estimates from Atlantic Flyway states (Florida north to Maine)

^c The SE of the goldeneyes estimate for 2013 is not reported due to insufficient counts.

Model Structures

We had sufficient pre-season bandings for American green-winged teal and wood ducks to estimate harvest rates directly from band recovery analysis, so we used a similar model to western mallards:

$$N_{t+1} = \left[N_t + N_t r \left(1 - \frac{N_t}{K} \right) \right] (1 - h_t),$$

where N = breeding population size, r = the maximum intrinsic growth rate, K = carrying capacity, and h = harvest rate estimated from banding data. The model does not have age or sex structure and banding summaries indicated reasonable sample sizes for adults and juveniles of both sexes, so we pooled all banding data when estimating an overall population harvest rate. This form of the discrete logistic model assumes that density dependent growth (or declines) are instantaneous and loss to harvest occurs following the instantaneous growth (i.e., next year's population is based on the current year population, density dependent growth, and surviving the hunting season at a rate equal to $[1 - h]$). This model assumes that harvest is additive and r and K provide a measure of the harvest potential for these species.

Because we did not have sufficient data to estimate harvest rates for ring-necked ducks and goldeneyes, we used a slightly modified version of the above model that includes total harvest rather than harvest rate:

$$N_{t+1} = \left[N_t + N_t r \left(1 - \frac{N_t}{K} \right) \right] - dH_t,$$

where H = total harvest in number of birds, and d = a scaling parameter to account for incomplete overlap between the spatial scale for which H and N are calculated (i.e., breeding population surveys are limited to a discrete region in eastern U.S. and Canada, whereas the harvest data can be collected from birds that breed outside of the survey region).

Estimation Framework

We used Bayesian estimation methods with a state-space model (Meyer and Millar 1999) to estimate the parameters of the discrete logistic model for all four species in the multi-stock framework. This modeling approach allows us to explicitly model the process (i.e., the unobservable true underlying dynamics of the population) and observation (sampling a portion of the population) components that generated the observed data. As recommended by Meyer and Millar (1999), we scaled N by K to help improve convergence and assumed that the process error was lognormally distributed. Therefore, the process model for American green-winged teal and wood ducks was:

$$\log(P_t) = \log([P_{t-1} + P_{t-1}r(1 - P_{t-1})](1 - h_{t-1})) + e_t,$$

whereas the process model for ring-necked ducks and goldeneyes was:

$$\log(P_t) = \log\left([P_{t-1} + P_{t-1}r(1 - P_{t-1})] - d\frac{H_{t-1}}{K}\right) + e_t,$$

with

$$P_t = N_t/K, \text{ and}$$

$$e_t \sim N(0, \sigma^2)$$

for both model structures. The process error (e_t) represents the inability of the discrete logistic model to accurately characterize population changes. We assumed that the standard errors for the breeding population size estimates were normally distributed and linked the process model to the observed data as:

$$N_t = P_t K + \varepsilon_t^{BPOP},$$

where

$$\varepsilon_t^{BPOP} \sim N(0, \sigma_{BPOP}^2).$$

The posterior estimates for the discrete logistic parameters for each species are listed in [Table F.2](#).

Table F.2 – Estimates of model parameters resulting from fitting a discrete logistic model to a time series of estimated population sizes and harvest rates of American green-winged teal (AGWT), wood ducks (WODU), ring-necked ducks (RNDU), and goldeneyes (GOLD) breeding in eastern Canada and the U.S. from 1998–2024.

Parameter	Species	Mean	SD	2.5% CI ^a	Median	97.5% CI
K	AGWT	0.5146	0.0665	0.4031	0.5036	0.6545
K	WODU	1.4581	0.1733	1.1572	1.4309	1.8312
K	RNDU	0.8970	0.1519	0.6629	0.8667	1.1978
K	GOLD	0.8264	0.1426	0.5934	0.7969	1.1254
P_0	AGWT	0.6080	0.0759	0.4492	0.6145	0.7404
P_0	WODU	0.6178	0.0651	0.4819	0.6275	0.7259
P_0	RNDU	0.6442	0.0633	0.5070	0.6511	0.7582
P_0	GOLD	0.6437	0.0948	0.4434	0.6481	0.8247
d	RNDU	0.5131	0.2780	0.0503	0.5245	0.9897
d	GOLD	0.5751	0.2834	0.0778	0.6113	1.0000
r	AGWT	0.4468	0.1116	0.2531	0.4325	0.6662
r	WODU	0.3747	0.0797	0.2406	0.3631	0.5315
r	RNDU	0.4240	0.1134	0.2241	0.4089	0.6478
r	GOLD	0.2357	0.0531	0.1397	0.2297	0.3415
σ^2	AGWT	0.0056	0.0061	0.0002	0.0037	0.0170
σ^2	WODU	0.0015	0.0012	0.0002	0.0011	0.0038
σ^2	RNDU	0.0033	0.0036	0.0002	0.0022	0.0100
σ^2	GOLD	0.0127	0.0138	0.0002	0.0083	0.0390

^a CI = credible interval.

Data—The USFWS and Atlantic Flyway agreed to use breeding population size data from the largest area possible for the multi-stock AHM framework. The complete eastern Canada and Maine area has been surveyed since 1998 and is the largest area representing breeding population sizes of American green-winged teal, ring-necked ducks, and goldeneyes that are harvested in the Atlantic Flyway. The BBS survey (1966–current) and AFBWS (1993–current) data that are used to estimate wood duck breeding population size provide a longer time series for that species in the Atlantic Flyway. However, changes in band inscriptions and the lack of an appropriate reporting rate for adjusting harvest rate for that species during the mid-1990s precluded us from estimating reliable harvest rates that were needed for the discrete logistic model. Therefore, we limited the data for all species to 1998–current for the Atlantic Flyway multi-stock AHM framework (see [Table F.1](#)).

Prior distributions—Inferences from Bayesian analyses are derived from posterior distributions that are proportional to the likelihood of the data given model parameters multiplied by the prior probabilities of those parameters. We used two different approaches for estimating prior distributions for K and r . For K , we used a uniform prior because we had no *a priori* information that could allow us to put more weight on a specific K for each species. However,

we felt we could identify endpoints for the uniform distribution as the mean observed population size (i.e., current harvest levels are completely compensatory) and double the mean observed population size (i.e., populations are currently being harvested at maximum sustainable yield [MSY] and are at $\frac{1}{2}K$). We extended the uniform prior 20% less and 20% greater than these end points to account for uncertainty in observational data. These prior values were based on observed breeding population sizes from 1998 to 2015, which represented the extent of the time series when the development of the multi-stock framework first began. We felt that we had a more justifiable theoretical basis to estimate a non-uniform prior for r based on previous research. For each species, we used the demographic invariant method (Niel and Lebreton 2005) with survival rate estimates based on an allometric relationship between species mass and survival in captive birds (Johnson et al. 2012) to develop informed lognormal priors (Table F.3). We used a non-informative inverse gamma prior for estimating process variation.

Table F.3 – Lognormal mean and standard deviations (SD) used to describe the prior distributions for maximum intrinsic growth rate (r) for American green-winged teal (AGWT), wood ducks (WODU), ring-necked ducks (RNDU), and goldeneyes (GOLD) in eastern Canada and U.S.

Species	Mean	SD
AGWT	-0.80396	0.23495
WODU	-0.89116	0.24417
RNDU	-0.90198	0.24294
GOLD	-1.42346	0.20831

Appendix G Modeling Waterfowl Harvest Rates

Mid-continent Mallards

We modeled harvest rates of mid-continent mallards within a Bayesian hierarchical framework. We developed a set of models to predict harvest rates under each regulatory alternative as a function of the harvest rates observed under the liberal alternative, using historical information. We modeled the probability of regulation-specific harvest rates (h) based on normal distributions with the following parameterizations:

$$\text{Closed: } p(h_C) \sim N(\mu_C, v_C^2)$$

$$\text{Restrictive: } p(h_R) \sim N(\mu_R, v_R^2)$$

$$\text{Moderate: } p(h_M) \sim N(\mu_M, v_M^2)$$

$$\text{Liberal: } p(h_L) \sim N(\mu_L, v_L^2)$$

For the restrictive and moderate alternatives we introduced the parameter γ to represent the relative difference between the harvest rate observed under the liberal alternative and the moderate or restrictive alternatives. Based on this parameterization, we are making use of the information that has been gained (under the liberal alternative) and are modeling harvest rates for the restrictive and moderate alternatives as a function of the mean harvest rate observed under the liberal alternative. For the harvest-rate distributions assumed under the restrictive and moderate regulatory alternatives, we specified that γ_R and γ_M are equal to the prior estimates of the predicted mean harvest rates under the restrictive and moderate alternatives divided by the prior estimates of the predicted mean harvest rates observed under the liberal alternative. Thus, these parameters act to scale the mean of the restrictive and moderate distributions in relation to the mean harvest rate observed under the liberal regulatory alternative. We also considered the marginal effect of framework-date extensions under the moderate and liberal alternatives by including the parameter δ_f .

To update the probability distributions of harvest rates realized under each regulatory alternative, we first needed to specify a prior probability distribution for each of the model parameters. These distributions represent prior beliefs regarding the relationship between each regulatory alternative and the expected harvest rates. We used a normal distribution to represent the mean and a scaled inverse-chi-square distribution to represent the variance of the normal distribution of the likelihood. For the mean (μ) of each harvest-rate distribution associated with each regulatory alternative, we use the predicted mean harvest rates provided in (U.S. Fish and Wildlife Service 2000, 13–14), assuming uniformity of regulatory prescriptions across Flyways. We set prior values of each standard deviation (v) equal to 20% of the mean (CV = 0.2) based on an analysis by Johnson et al. (1997). We then specified the following prior distributions and parameter values under each regulatory package:

Closed (in U.S. only):

$$p(\mu_C) \sim N\left(0.0088, \frac{0.0018^2}{6}\right)$$

$$p(v_C^2) \sim \text{Scaled Inv} - \chi^2(6, 0.0018^2)$$

These closed-season parameter values are based on observed harvest rates in Canada during the 1988–93 seasons, which was a period of restrictive regulations in both Canada and the United States.

For the restrictive and moderate alternatives, we specified that the standard error of the normal distribution of the scaling parameter is based on a coefficient of variation for the mean equal to 0.3. The scale parameter of the inverse-chi-square distribution was set equal to the standard deviation of the harvest rate mean under the restrictive and moderate regulation alternatives (i.e., CV = 0.2).

Restrictive:

$$p(\gamma_R) \sim N\left(0.51, \frac{0.15^2}{6}\right)$$

$$p(v_R^2) \sim \text{Scaled Inv} - \chi^2(6, 0.0133^2)$$

Moderate:

$$p(\gamma_M) \sim N\left(0.85, \frac{0.26^2}{6}\right)$$

$$p(v_r^2) \sim \text{Scaled Inv} - \chi^2(6, 0.0223^2)$$

Liberal:

$$p(\mu_L) \sim N\left(0.1305, \frac{0.0261^2}{6}\right)$$

$$p(v_R^2) \sim \text{Scaled Inv} - \chi^2(6, 0.0261^2)$$

The prior distribution for the marginal effect of the framework-date extension was specified as:

$$p(\delta_f) \sim N(0.02, 0.01^2)$$

The prior distributions were multiplied by the likelihood functions based on the last 26 years of data under liberal regulations, and the resulting posterior distributions were evaluated with Markov chain Monte Carlo simulation. Posterior estimates of model parameters and of annual harvest rates are provided in [Table G.1](#).

Western Mallards

We modeled harvest rates of western mallards using a similar parameterization as that used for mid-continent mallards. However, we did not explicitly model the effect of the framework date extension because we did not use data observed prior to when framework date extensions were available. In the western mallard parameterization, the effect of the framework date extensions are implicit in the expected mean harvest rate expected under the liberal regulatory option.

$$\text{Closed: } p(h_C) \sim N(\mu_C, v_C^2)$$

$$\text{Restrictive: } p(h_R) \sim N(\gamma_R \mu_L, v_R^2)$$

$$\text{Moderate: } p(h_M) \sim N(\gamma_M \mu_L, v_M^2)$$

$$\text{Liberal: } p(h_L) \sim N(\mu_L, v_L^2)$$

We set prior values of each standard deviation (v) equal to 30% of the mean ($CV = 0.3$) to account for additional variation due to changes in regulations in the other Flyways and their unpredictable effects on the harvest rates of western mallards. We then specified the following prior distribution and parameter values for the liberal regulatory alternative:

Table G.1 – Parameter estimates for predicting mid-continent mallard harvest rates resulting from a hierarchical, Bayesian analysis of mid-continent mallard band-recovery information from 1998–2023.

Parameter	Estimate	SD	Parameter	Estimate	SD
μ_C	0.0088	0.0021	h_{1998}	0.1020	0.0067
ν_C	0.0019	0.0005	h_{1999}	0.0984	0.0069
γ_R	0.5107	0.0614	h_{2000}	0.1226	0.0082
ν_R	0.0129	0.0033	h_{2001}	0.0931	0.0084
γ_M	0.8481	0.1041	h_{2002}	0.1213	0.0041
ν_M	0.0215	0.0054	h_{2003}	0.1104	0.0040
μ_L	0.1068	0.0057	h_{2004}	0.1294	0.0047
ν_L	0.0156	0.0020	h_{2005}	0.1144	0.0054
δ_f	0.0039	0.0060	h_{2006}	0.1030	0.0042
			h_{2007}	0.1127	0.0040
			h_{2008}	0.1180	0.0044
			h_{2009}	0.1010	0.0036
			h_{2010}	0.1107	0.0049
			h_{2011}	0.0965	0.0057
			h_{2012}	0.1028	0.0047
			h_{2013}	0.1044	0.0051
			h_{2014}	0.1098	0.0062
			h_{2015}	0.1015	0.0065
			h_{2016}	0.1120	0.0069
			h_{2017}	0.1054	0.0046
			h_{2018}	0.0984	0.0044
			h_{2019}	0.0996	0.0047
			h_{2020}	0.1083	0.0084
			h_{2021}	0.1097	0.0034
			h_{2022}	0.1107	0.0048
			h_{2023}	0.1144	0.0068

Table G.2 – Parameter estimates for predicting western mallard harvest rates resulting from a hierarchical, Bayesian analysis of western mallard band-recovery information from 2008–2023.

Parameter	Estimate	SD	Parameter	Estimate	SD
μ_C	0.0088	0.0011	h_{2008}	0.1495	0.0065
v_C	0.0182	0.0046	h_{2009}	0.1371	0.0058
γ_R	0.5124	0.0634	h_{2010}	0.1390	0.0061
v_R	0.0173	0.0044	h_{2011}	0.1266	0.0055
γ_M	0.8548	0.1032	h_{2012}	0.1328	0.0056
v_M	0.0287	0.0073	h_{2013}	0.0939	0.0047
μ_L	0.1423	0.0065	h_{2014}	0.1613	0.0071
v_L	0.0270	0.0041	h_{2015}	0.1557	0.0070
			h_{2016}	0.1593	0.0079
			h_{2017}	0.1573	0.0078
			h_{2018}	0.1272	0.0059
			h_{2019}	0.1408	0.0063
			h_{2020}	0.1652	0.0069
			h_{2021}	0.1552	0.0052
			h_{2022}	0.1875	0.0086
			h_{2023}	0.1541	0.0077

Closed (in US only):

$$p(\mu_C) \sim N\left(0.0088, \frac{0.00264^2}{6}\right)$$

$$p(v_C^2) \sim \text{Scaled Inv} - \chi^2(6, 0.00264^2)$$

Restrictive:

$$p(\gamma_R) \sim N\left(0.51, \frac{0.153^2}{6}\right)$$

$$p(v_R^2) \sim \text{Scaled Inv} - \chi^2(6, 0.01867^2)$$

Moderate:

$$p(\gamma_M) \sim N\left(0.85, \frac{0.255^2}{6}\right)$$

$$p(v_R^2) \sim \text{Scaled Inv} - \chi^2(6, 0, 0.03112^2)$$

Liberal:

$$p(\mu_L) \sim N\left(0.1220, \frac{0.03661^2}{6}\right)$$

$$p(v_R^2) \sim \text{Scaled Inv} - \chi^2(6, 0.03661^2)$$

The prior distributions were multiplied by the likelihood functions based on the last 16 years of data under liberal regulations, and the resulting posterior distributions were evaluated with Markov chain Monte Carlo simulation. Posterior estimates of model parameters and of annual harvest rates are provided [Table G.2](#).

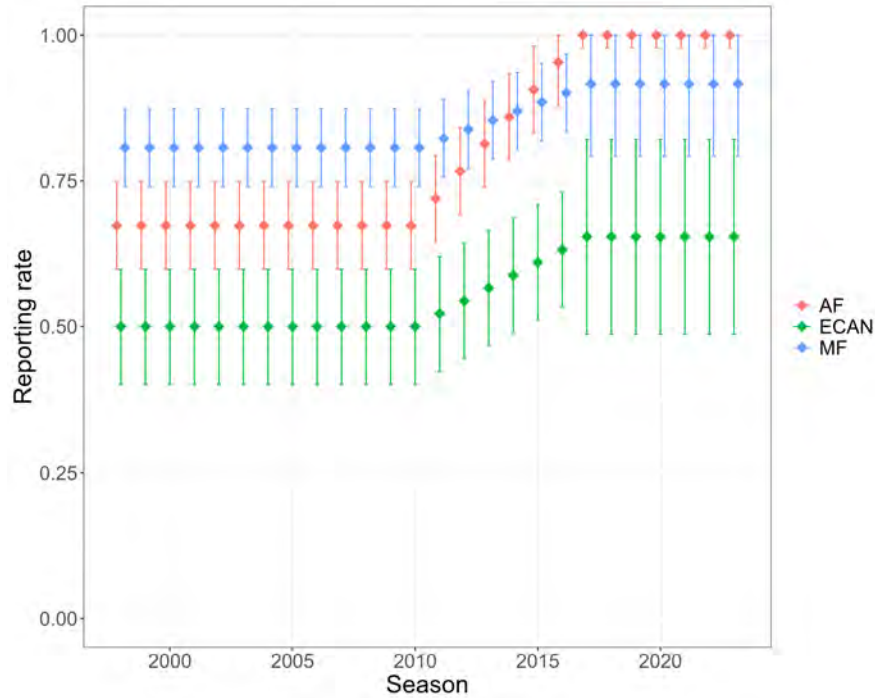

Figure G.1 – Updated reporting rates by region of recovery (AF = Atlantic Flyway, ECAN = eastern Canada, MF = Mississippi Flyway) and hunting season. Error bars represent 95% credibility intervals.

Eastern Waterfowl Stocks

We estimated expected harvest rates and associated variances for American green-winged teal and wood ducks as a function of the Atlantic Flyway’s liberal regulatory alternative using birds banded in eastern Canada and the Atlantic Flyway during 1998–2023 (banding reference areas 8, 15, 16; the states of North Carolina, South Carolina, Georgia, and Florida; the provinces of New Brunswick, Nova Scotia, Newfoundland and Labrador, Prince Edward Island, and eastern Quebec). We used these bands and their direct recoveries in binomial models to estimate direct recovery probabilities and then adjusted those recovery probabilities with regional reporting rates (birds banded in these areas were recovered in eastern Canada, the Atlantic Flyway, and Mississippi Flyway; Boomer et al. 2013, Garrettson et al. unpublished data, Boomer et al. unpublished data) to estimate harvest rates (U.S. Fish and Wildlife Service 2017). We pooled age and sex classes for this estimation because the discrete logistic model used for this assessment does not incorporate age and sex structure. We used Bayesian methods and Markov chain Monte Carlo (MCMC) methods to estimate annual recovery probabilities and adjusted the recovery probabilities within the MCMC to obtain variances and incorporate uncertainty in the estimates of reporting rates (Padding et al. 2018).

In 2024 we updated reporting rates for American green-winged teal and wood ducks using recent reward banding studies (Garrettson et al. unpublished data, Boomer et al. unpublished data). We updated the reporting rate for recoveries in the Mississippi Flyway using updated mid-continent mallard reporting rates (2017–2022, Boomer et al. unpublished data), and we updated recoveries in the U.S. Atlantic Flyway and eastern Canada using updated black duck reporting rates (2017–2019, Garrettson et al. unpublished data). We used a simple linear trend to impute reporting rates in years between original and updated reporting rate estimates (Figure G.1). For imputed years, we carried forward the variance associated with original reporting rate estimates. We used the updated time series of harvest rate estimates for American green-winged teal and wood ducks (Table G.3) to calculate expected harvest rate distributions under different policy alternatives (see below).

Banding and recovery data were insufficient for estimating the expected ring-necked duck and goldeneye harvest rates, so we used annual estimates of harvest (H) from the Harvest Information Program and the fall population size to make inferences about harvest rate (Runge et al. 2004). We estimated the annual fall population size (NF) from

the discrete logistic model, and then estimated the expected harvest rate as H/NF (Runge et al. 2004). Therefore, the estimates of harvest rate for ring-necked ducks and goldeneyes were both calculated as derived parameters in the discrete logistic model used to estimate r and K for the population. We used Bayesian methods and a state-space model to fit the discrete logistic models and calculate derived estimates of harvest rate for these species (Appendix F). Breeding population estimates for ring-necked ducks and goldeneyes in eastern North America were available beginning in 1998, therefore we estimated the expected harvest rate for both species based on 1998–2023 harvest and population estimates.

Table G.3 – Annual harvest rate estimates (h) and associated standard errors (SE) for American green-winged teal (AGWT), wood ducks (WODU), ring-necked ducks (RNDU), and goldeneyes (GOLD) in eastern Canada (WBPHS strata 51–53, 56, 62–72) and the U.S. (Atlantic Flyway states) from 1998–2023. Reporting rate estimates for AGWT and WODU were updated in 2024 resulting in an updated time series of harvest rate estimates.

Year	AGWT ^a		WODU ^a		RNDU ^b		GOLD ^b	
	h	SE	h	SE	h	SE	h	SE
1998	0.1790	0.0253	0.1094	0.0077	0.2324	0.0184	0.0444	0.0056
1999	0.1334	0.0096	0.1265	0.0083	0.1770	0.0155	0.0358	0.0046
2000	0.1351	0.0092	0.1206	0.0077	0.1217	0.0123	0.0349	0.0046
2001	0.1103	0.0089	0.1393	0.0086	0.1127	0.0115	0.0260	0.0035
2002	0.1025	0.0085	0.1258	0.0074	0.1133	0.0113	0.0279	0.0038
2003	0.1256	0.0090	0.1173	0.0080	0.1204	0.0119	0.0318	0.0044
2004	0.1032	0.0097	0.1094	0.0073	0.0881	0.0087	0.0329	0.0046
2005	0.0991	0.0088	0.1137	0.0071	0.1190	0.0110	0.0385	0.0057
2006	0.1041	0.0095	0.1085	0.0065	0.1470	0.0134	0.0292	0.0045
2007	0.1044	0.0079	0.1076	0.0066	0.1215	0.0119	0.0294	0.0044
2008	0.1112	0.0084	0.1193	0.0072	0.1316	0.0127	0.0307	0.0047
2009	0.1043	0.0092	0.1122	0.0065	0.1193	0.0119	0.0269	0.0043
2010	0.1156	0.0088	0.1466	0.0084	0.0992	0.0099	0.0269	0.0044
2011	0.1044	0.0077	0.1218	0.0066	0.1511	0.0144	0.0295	0.0049
2012	0.1038	0.0082	0.1307	0.0068	0.1804	0.0182	0.0286	0.0050
2013	0.1021	0.0082	0.1025	0.0055	0.1462	0.0168	0.0295	0.0055
2014	0.0881	0.0072	0.1283	0.0063	0.1233	0.0146	0.0185	0.0035
2015	0.1119	0.0101	0.1009	0.0049	0.1270	0.0151	0.0154	0.0030
2016	0.0888	0.0082	0.0993	0.0049	0.1329	0.0158	0.0195	0.0037
2017	0.0892	0.0088	0.1227	0.0047	0.1058	0.0128	0.0189	0.0035
2018	0.0808	0.0074	0.0946	0.0039	0.1198	0.0141	0.0171	0.0032
2019	0.0904	0.0086	0.0997	0.0039	0.0760	0.0091	0.0183	0.0034
2020	0.1000	0.0096	0.1174	0.0043	0.0971	0.0108	0.0153	0.0027
2021	0.0939	0.0079	0.1113	0.0045	0.0886	0.0094	0.0134	0.0022
2022	0.1067	0.0094	0.1117	0.0043	0.0881	0.0086	0.0071	0.0010
2023	0.1151	0.0071	0.1303	0.0052	0.1326	0.0122	0.0153	0.0018

^a Estimated from band recovery data.

^b Estimated from a fall flight and total harvest.

The Atlantic Flyway has not experienced more restrictive duck hunting regulations (e.g., 30-day season and a 3-bird limit) since the early 1990s. Furthermore, preseason duck banding efforts in eastern North America were limited until the 1990s. Therefore, we relied on data collected through the annual USFWS’s Parts Collection Survey (PCS) to estimate expected harvest rates during seasons < 60 days and/or bag limits < 6 birds as a proportion of the liberal package (see Padding et al. 2018 for details). We used daily bag composition data from the PCS to estimate the proportional reduction in harvest of each species that was expected to result from smaller bag limits under the moderate and restrictive regulatory alternatives (bag limit effect), following methods described by Martin and Carney (1977) and Balkcom et al. (2010). For each of the four species, we then summed the expected Flyway-wide reductions

Table G.4 – Parameter estimates for predicting American green-winged teal (AGWT), wood duck (WODU), ring-necked duck (RNDU), and goldeneye (GOLD) expected harvest rates for season lengths < 60 days and bag limits < 6 birds.

Parameter	AGWT	WODU	RNDU	GOLD
γ_C	0.1413	0.0484	0.1904	0.1848
γ_R	0.4872	0.6048	0.4427	0.2759
γ_M	0.7607	0.7339	0.7405	0.5172

due to reduced season lengths and the expected reduction due to a smaller bag limits to estimate total expected reductions as proportions of the harvest under the liberal regulatory alternative (i.e., we estimated a γ_M , γ_R , γ_C for each species). Therefore, we estimated the expected harvest rate under the closed, moderate, and restrictive alternatives as

$$h_i = h_L \times \gamma_i,$$

where i indexes moderate, restrictive, or closed seasons in the U. S.

To estimate the expected effect of a January 31 ending framework date for the liberal and moderate alternatives, we relied on the observed effect of a 16-day framework date extension implemented in 2002 that increased the mallard harvest rate by 0.0052 (U.S. Fish and Wildlife Service 2017, Appendix G). We estimated a mean additional extension of 3 days for the January 31 fixed ending date, and assumed that the effect per day would be the same as the observed per day effect of the previous extension. The resulting predicted increase in harvest rate ($3/16 \times 0.0052 = 0.000975$) was added to the expected harvest rate estimates for the liberal and moderate alternatives.

Appendix H Northern Pintail Models

In 2010, the USFWS and Flyway Councils adopted an adaptive management framework to inform northern pintail harvest management (U.S. Fish and Wildlife Service 2010). Based on this original formulation, the northern pintail adaptive harvest management protocol considered two population models that represent alternative hypotheses about the effect of harvest on population dynamics: one in which harvest is additive to natural mortality, and another in which harvest is compensatory to natural mortality according to density dependent post-harvest survival.

After 10 years of experience with pintail AHM, the Flyway councils were interested in revisiting many of the key technical and policy aspects of the pintail AHM framework through a “double-loop” learning process (Lee 1993) in an effort to revise the protocols that inform pintail harvest regulations. A fully Integrated Population Model (IPM) was developed to better represent pintail population and harvest dynamics after extensive collaboration and technical work coordinated by the Pintail Working Group (Boomer et al. 2024). Based on these updated results, the Flyways and the FWS recommended the adoption of an interim AHM framework to inform pintail harvest regulations for the 2025–26 hunting season. Here, we describe the technical details of the revised northern pintail population model.

Population Model

The original population model that supported the development of pintail AHM did not rely on a typical “balance equation” characteristic of most waterfowl AHM frameworks, where changes in population size are broken down into juvenile and adult components of the population over an annual cycle (Johnson et al. 1997). A more simplified structure was employed because of a lack of detailed demographic data (e.g., age- and sex- specific harvest rates) to support the added biological complexity. To overcome some of these structural limitations, we developed a post-census, age- and sex-structured integrated population model (IPM, Besbeas et al. 2002, Arnold et al. 2018), which allowed us to evaluate the major sources of available pintail monitoring information in a common estimation framework. With this approach, we were able to include more biological realism in the form of a proper balance equation to model annual changes in pintail populations (Figure H.1). In addition, because preseason banding operations generally occur in August, the annual cycles of population change and survival are not consistent temporally which also requires some adjustments to how mortality is structured in the population model and estimated in the survival model (Runge et al. 2002). Based on this parameterization, the total breeding population is divided into male and female fractions according to the year-specific male fraction (m_t). Adult males (N_{am}) then survive to the next year based on an age and sex-specific survival rate (S_{am}). Adult females (N_{af}) breed after surviving the breeding season according to the spring-summer survival rate (SS_f). Annual recruitment of juveniles of each sex is the product of the number of surviving adult females and the recruitment rate (R_t), which is derived from female age ratios. We assume an equal sex ratio for juveniles (N_{juv}) that then survive the remainder of the annual cycle and become adults the following spring just before the breeding season.

A key feature of our population model is that the anniversary date for our state dynamics occurs after the Waterfowl Breeding Population and Habitat Survey (WBPHS, U.S. Fish and Wildlife Service 2019) resulting in a May(t) to May($t+1$) annual cycle. In addition, the control variable in the current pintail AHM framework is total continental harvest as measured through the national Harvest Information Program (HIP, Raftovich et al. 2023). From a harvest management standpoint, we are interested in the size of the fall flight that occurs in September, so we can predict total expected harvest when deriving regulatory policies. One of the benefits of using an IPM is that we can estimate the fall flight which otherwise is unobservable with current monitoring programs. Accordingly, the fall flight is calculated with

$$ff_{a,f,t} = N_t(1 - m_t)SS_f, \quad (1)$$

$$ff_{a,m,t} = N_t(m_t)SS_m, \quad (2)$$

$$ff_{j,f,t} = N_t(1 - m_t)SS_f\gamma R_t, \quad (3)$$

$$ff_{j,m,t} = N_t(m_t)SS_m\gamma R_t, \quad (4)$$

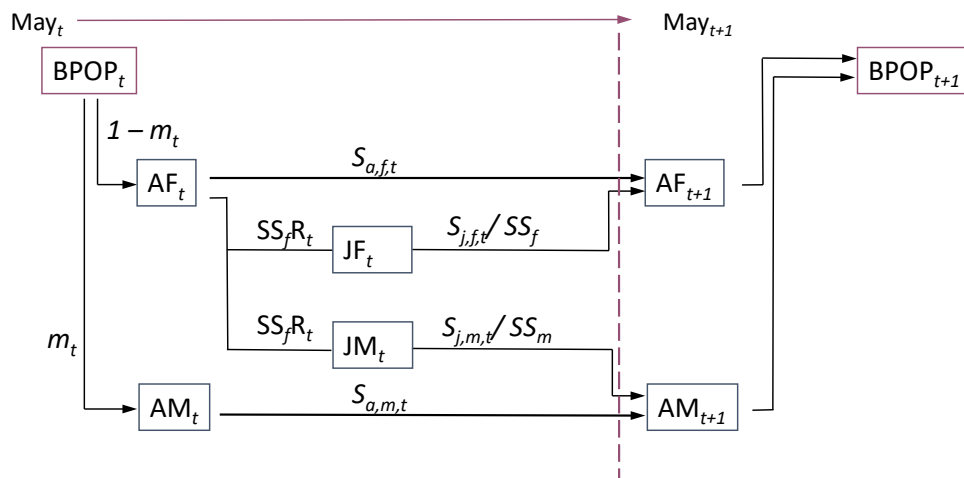

Figure H.1 – A diagram that describes the population model developed to represent annual pintail population dynamics. With this formulation, the total spring breeding population (BPOP) is divided into adult males (AM) and adult females (AF) according to the male fraction (m). Juvenile males (JM) and juvenile females (JM) are recruited to the population based on the recruitment rate derived from the female age ratio (R_t) and spring-summer survival rates (SS_{sex}). Individuals that survive ($S_{age,sex,t}$) over the annual cycle then enter the next year's breeding population in year $t + 1$.

where,

$ff_{age,sex,t}$ are the cohort-specific contributions to the fall flight in year t ,

m_t is the male fraction in year t ,

SS_{sex} is the spring-summer survival rate for each sex, and

R_t is the female age ratio in year t .

For the juvenile contribution of the fall flight, we introduce a parameter γ_R as a correction term used to account for balance equation bias. In many instances where waterfowl population models are built with data from pre-season banding data, harvest data, and breeding population estimates from the WBPHS, the resulting population model results in a systematic overprediction (Martin et al. 1979, Runge et al. 2002). Typically, a correction term is used to eliminate this bias with a post hoc assessment of model predictions (see Runge et al. 2002). In our formulation, we have adjusted annual recruitment with a bias term that is estimated within the dynamics of the IPM.

With the cohort-specific estimates of the fall flight, we can then predict the total harvest as a function of the harvest rates resulting from the Brownie dead recovery model embedded within the IPM (see section H Survival Sub-models) according to

$$H_{a,f,t} = ff_{a,f,t} h_{a,f,t}, \quad (5)$$

$$H_{a,m,t} = ff_{a,m,t} h_{a,m,t}, \quad (6)$$

$$H_{j,f,t} = ff_{j,f,t} h_{j,f,t}, \quad (7)$$

$$H_{j,m,t} = ff_{j,m,t} h_{j,m,t}, \quad (8)$$

$$H_{tot} = H_{a,f,t} + H_{a,m,t} + H_{j,f,t} + H_{j,m,t}. \quad (9)$$

We then predict the number of individuals that survive until the following year based on survival rates resulting from the Brownie dead recovery model embedded within the IPM (see section H Survival Sub-models) according to

$$N_{a,f,t+1}^{pred} = (ff_{a,f,t} S_{a,f,t} / SS_f) + (ff_{j,f,t} S_{j,f,t} / SS_f), \text{ and} \quad (10)$$

$$N_{a,m,t+1}^{pred} = (ff_{a,m,t} S_{a,m,t} / SS_m) + (ff_{j,m,t} S_{j,m,t} / SS_m). \quad (11)$$

We can also update the estimate of the male fraction of the population for the next year with

$$m_{t+1} = \frac{N_{a,m,t+1}^{pred}}{N_{a,f,t+1}^{pred} + N_{a,m,t+1}^{pred}}. \quad (12)$$

Recruitment Sub-model

We used age ratio information from the USFWS Parts Collection Survey (PCS, Raftovich et al. 2023) from 1961–2018 to model annual recruitment (Runge and Boomer 2005, Osnas et al. 2021). The PCS samples hunter-shot wings and estimates the proportion of each sex and age class (e.g., *juvenile* : *adult* female) in the hunted population. Because, raw age ratios may be biased due to hunter selectivity, age ratios are typically adjusted for differential vulnerability with direct recovery information (recoveries of birds from the first hunting season after banding) from pre-season banding programs (Martin et al. 1979). We followed the methods of Zimmerman et al. (2010), to structure our recruitment model. With this formulation we start with estimating direct recovery rates for adult and juvenile females each year as the rate parameter from the binomial distribution

$$Recs_{j,t} \sim \text{Binomial}(Rel_{j,t}, f_{j,t}), \quad (13)$$

$$Recs_{a,t} \sim \text{Binomial}(Rel_{a,t}, f_{a,t}), \quad (14)$$

$$v_t = f_{j,t}/f_{a,t} \quad (15)$$

where,

$Recs_{j,t}$ is the number of direct recoveries of juvenile female birds in year t ,

$Recs_{a,t}$ is the number of direct recoveries of adult female birds in year t ,

$Rel_{j,t}$ is the number of pre-season banded juvenile female birds in year t ,

$Rel_{a,t}$ is the number of pre-season banded adult female birds in year t , and

$f_{j,t}$ is the direct recovery rate for juvenile female birds in year t ,

$f_{a,t}$ is the direct recovery rate for adult female birds in year t ,

v_t is the juvenile to adult differential vulnerability in year t .

Previous work modeling pintail recruitment found that pintail age ratios are negatively related to increasing population size (density dependent) and sensitive to the average latitude at which the pintail breeding population distribution is observed each spring (Runge and Boomer 2005, Osnas et al. 2016). Therefore, we developed a log-linear model to predict pintail female age ratios as a function of the true breeding population size and the average latitude of the distribution of the pintail breeding population. To facilitate better sampling in our estimation, each predictor was centered by subtracting the mean from each covariate. We modeled the predicted age ratio (μ_t^R) on the log scale in year t with

$$\log(\mu_t^R) = \beta_0 + \beta_1 N_t + \beta_2 Lat_t, \text{ and} \quad (16)$$

$$R_t \sim \text{Normal}\left(\mu_t^R, \sigma_R^2\right), \quad (17)$$

assuming that errors were normally distributed and governed by the variance term (σ_R^2). Here the β terms are the linear model parameters with N_t equal to the true pintail population size in year t and Lat_t equal to the mean latitude of the pintail breeding population observed in year t . For these data, the mean latitude is the mean of the survey stratum centroids in the WBPHS weighted by the strata-specific population sizes observed each year.

We then defined the likelihood contribution for the proportion of the number of juvenile female wings in the total wing sample as

$$w_{j,t} \sim \text{Binomial}(W_{tot,t}, q_t), \quad (18)$$

where,

$w_{j,t}$ are the number of juvenile female wings estimated from the PCS in year t ,

$W_{tot,t}$ are the number of female wings of both ages estimated from the PCS in year t , and the probability of obtaining a juvenile wing is

$$q_t = \frac{R_t v_t}{1 + R_t v_t}. \quad (19)$$

Survival Sub-models

A substantial source of uncertainty that challenges waterfowl harvest managers results from a lack of knowledge regarding the true underlying relationship between harvest mortality and annual survival (Nichols et al. 1995a, Cooch et al. 2014). Often, managers think about two models for this relationship, an additive model that specifies how

any harvest mortality proportionately increases total mortality, and a compensatory model that states that harvest mortality may be compensated for by changes in natural mortality, often as a result of density dependence (Anderson and Burnham 1976). Questions about which model may be operating in harvested waterfowl populations become important because the choice of what regulatory strategy to employ depends on which model one uses to derive harvest policies (Anderson 1975). Most of the original AHM frameworks were designed to resolve this structural uncertainty with the specification of a discrete model set that explicitly included models representing the endpoints of the relationship between harvest mortality and annual survival (i.e., fully additive or fully compensatory; Johnson et al. 1997). Over time, changes in relative credibility measures (weights) associated with each of these models formed a basis for learning and adaptation as annual updates to model weights were used to derive harvest policies (Nichols et al. 2015). One of the potential drawbacks to this passive approach to adaptive management is that learning may be slower compared to active adaptive management which explicitly accounts for learning in the derivation of harvest policies (Williams et al. 2002). In addition, we have to assume that model parameterizations remain constant and that the model set remains relevant as the system evolves over time. Recent work focused on the predictive ability of the original mid-continent mallard model set highlights the need to actively test model performance over time while re-evaluating models designed to resolve structural uncertainty (Koons et al. 2022). Early discussions with the PWG highlighted some dissatisfaction with the pintail AHM model set and the limited ability to discern between the additive and compensatory models (U.S. Fish and Wildlife Service 2020). As a result, we chose to represent the relationship between harvest mortality and annual survival with a single functional form that admits a wide range of possible outcomes, including partial compensation (Conroy and Krementz 1990, Williams et al. 2002). With this approach, the relationship between harvest mortality and annual survival is determined by the pintail monitoring information and informed by the results of the IPM. We modeled annual survival as a function of annual harvest rate for each cohort with an ultra-structural approach (Burham and Anderson 1984) according to

$$S_{a,s,t} = \min\{S_{0,a,s}(1 - \beta 1_{a,s}K_{a,s,t}), 1 - K_{a,s,t}\} \quad (20)$$

where

$S_{a,s,t}$ are annual survival probabilities for individuals of age a (juvenile or adult), sex s (male or female) in year t ,
 $S_{0,a,s}$ are the survival probabilities expected in the absence of harvest for individuals of age a and sex s ,
 $\beta 1_{a,s}$ is a slope term that determines the strength of additivity between harvest and natural mortality for individuals of age a and sex s , and
 $K_{a,s,t}$ is the probability of being killed during the hunting season for individuals of age a (juvenile or adult), sex s (male or female) in year t .

We estimated the probability of being killed during the hunting season ($K_{a,s,t}$) by dividing harvest probabilities by $(1 - C)$ where C is the crippling loss rate and equal to 0.2 (Anderson and Burnham 1976). Harvest probabilities for each cohort were adjusted with band reporting probabilities estimated from a meta analysis of mallard (*Anas platyrhynchos*) reward band studies (Henny and Burnham 1976, Nichols et al. 1991, Boomer et al. 2013) described in Osnas et al. (2021) to estimate the recovery rate parameter of the Brownie model (Brownie et al. 1985). We extended the time series of reporting probabilities used by Osnas et al. (2021) with preliminary estimates of the most recent reward band study focused on mid-continent mallards (Boomer et al. 2023). The recovery probability a banded bird was shot, retrieved, and reported to the USGS Eastern Ecological Research Center Bird Banding Laboratory (BBL) was modeled conditional on whether the band report was solicited

$$f_{a,s,t}^S = h_{a,s,t}\gamma_t, \quad (21)$$

or unsolicited

$$f_{a,s,t}^U = h_{a,s,t}(1 - \gamma_t)\lambda_t, \quad (22)$$

where,

$h_{a,s,t}$ are the harvest probabilities for individuals of age a , sex s in year t ,
 γ_t is the solicitation probability in year t , and

λ_t is a band reporting probability in year t . Note we assume the band reporting rate is equal to 1.0 for solicited bands (Williams et al. 2002).

We used a random effects modeling approach for estimating harvest and solicitation rates assuming a normal distribution governed by an overall mean and variance. With this parameterization, annual harvest and solicitation rates were modeled on the logit scale with

$$\text{logit}(h_{a,s,t}) \sim \text{Normal}(\mu_{a,s}^h, \sigma_{a,s}^{2,h}) \quad (23)$$

$$\text{logit}(\gamma_t) \sim \text{Normal}(\mu_{sol}, \sigma_{sol}^2) \quad (24)$$

where,

$\mu_{a,s}$ is the mean harvest rate for individuals of age a , sex s ,

$\sigma_{a,s}^{2,h}$ is the variance of the harvest rate for individuals of age a , sex s ,

μ_{sol} is the mean solicitation rate for pintails,

σ_{sol}^2 is the variance of the solicitation rate for pintails.

We used band recovery data from the BBL to estimate survival, recovery, and harvest rates of adult, juvenile, male, and female pintails. We pulled banding and dead recovery information for normal, wild birds banded pre-season. We used dead recoveries of birds shot or found dead during the hunting season. Because a sizable number of pintail recoveries were determined to be solicited (bands reported not by the original finder or reported at the direction of another individual) based on “who” and “why” encounter codes, we post-stratified recoveries into solicited or unsolicited recoveries, assuming a solicited band was reported at a probability equal to 1.0. This additional structure allowed us to formally estimate the solicitation rate while also accounting for variation in reporting probabilities when estimating harvest rates. To account for this additional structure, the band recovery information was sorted into an m -array, where each row (i) represents the number of releases each year through (T) total years of banding. Each column (j) then represents the number of recoveries ($m_{i,j}$) for each year after banding, where the final column has the number of bands not recovered (Table H.4). Based on this data structure, we can specify that the likelihood contribution of each row of the m -array is given by a multinomial distribution governed by the cell probabilities defined by the expected number of recoveries according to

$$\text{Recs}_{a,s,t:2T+1} \sim \text{Multinomial}(\text{probs}_{a,s,t:2T+1}, \text{Rel}_{a,s,t}), \quad (25)$$

where,

$\text{Recs}_{a,s,t:2T+1}$ are the observed recoveries for individuals of age a , sex s released in year t and recovered in years $t : 2T + 1$,

$\text{probs}_{a,s,t:2T+1}$ are the multinomial cell probabilities for individuals of age a , sex s released in year t , and recovered in years $t : 2T + 1$, and

$\text{Rel}_{a,s,t}$ are the number of individuals of age a , sex s released in year t .

State-space Estimation

We used a Bayesian, state-space estimation framework to formally represent changes in the true (i.e., latent) population size and estimate the process variance. We related the true population size (N_t) to model predictions (N_t^{pred}) assuming multiplicative errors. Probabilistically, we assumed that the true population size could be modeled with a lognormal distribution according to

$$N_t \sim \text{Lognormal} \left(\log(N_t^{\text{pred}}), \sigma_{\text{process}}^2 \right) \quad (26)$$

with a mean specified by the year-specific model prediction and a process error variance that is estimated within the Bayesian framework.

Observation models

Annual monitoring data describing total breeding population sizes for pintails are estimated with the WBPBS (U.S. Fish and Wildlife Service 2019). For the purposes of AHM, pintail populations are defined as those breeding in WBPBS strata 1–18, 20–50, and 75–77 (Smith 1995). The reliability of pintail breeding population estimates may be impacted by the settling behavior of pintails each spring. When water conditions on the prairies are poor, pintails overfly these drier habitats and settle farther north, but as a result, pintail breeding population estimates tend to be lower in these overflight years. Runge and Boomer (2005) derived a relationship to “correct” for this bias in the breeding population as a function of the average latitude of the pintail breeding population distribution. For the period in which comparisons were possible (1961–2019), we related the observed breeding population estimates to the true, unobserved population sizes with this observation model

$$N_t^{obs} \sim Normal\left(e^{\log(N_t) + (\beta_{Lat} Lat_t - 51.68)}, \sigma_{obs,t}^2\right) \quad (27)$$

where,

β_{Lat} is a slope parameter that determines how much the breeding population decreases for a concomitant increase in latitude,

Lat_t is the mean latitude of the WBPBS strata centroids weighted by breeding population size observed in year t ,

and

$\sigma_{obs,t}^2$ are assumed known and estimated each year from the WBPBS observations.

As the pintail AHM decision framework was being evaluated, the PWG raised questions related to possible scaling issues between model-based predictions of harvest from the IPM and the information available from the Migratory Bird Harvest Information Program (HIP Raftovich et al. 2023, U.S. Fish and Wildlife Service 2020). Historically, we assumed that harvest models estimated with observed data that predict harvest outcomes from regulatory changes scale appropriately with the underlying demographic models used to predict population change. Because previous assessment work has found evidence of directional positive bias in total harvest estimates (Padding and Royle 2012, Boomer and Johnson 2007) we were interested in determining how the expected harvest represented in the IPM scaled with the observed harvest data. Therefore, we estimated the potential bias between the predicted harvest from the IPM and the total harvest estimates from the HIP assuming differences were normally distributed

$$H_t^{obs} \sim Normal\left(\gamma_H H_{tot}, \sigma_{HIP,t}^2\right) \quad (28)$$

where,

γ_H is a bias term that determines the difference between the total harvest estimated with the population model and observations from the HIP and

$\sigma_{HIP,t}^2$ are assumed known and estimated each year from the HIP assuming a coefficient of variation equal to 0.15.

Bayesian Estimation

We developed a Bayesian modeling framework to estimate the parameters and state dynamics represented in the IPM. We used the sampling distributions for the observed data described above, and specified prior distributions (Table H.5) for model parameters and unobserved system states. The resulting posterior distribution was evaluated with Markov chain Monte Carlo (MCMC) methods with program Stan (Stan 2024) through the cmdstanr package (Gabry et al. 2024) in program R (R Core Team 2023). We simulated 4 chains for 4,000 iterations, discarding the first 2,000 as burn-in. We inspected each chain and evaluated the R-hat convergence diagnostic (Vehtari et al. 2021) for each parameter to monitor chain convergence.

Table H.1 – Summary of posterior statistics for the scaling parameters estimated with the pintail IPM.

variable	mean	median	sd	q2.5	q97.5	rhat	ess_bulk	ess_tail
γ_R	0.565	0.565	0.030	0.508	0.625	1.000	6,976	6,100
γ_H	2.425	2.421	0.129	2.185	2.693	1.002	3,070	4,260
β_{Lat}	-0.068	-0.069	0.008	-0.083	-0.053	1.008	1,113	2,177

Parameter Estimates

The IPM successfully reconstructed observed pintail population dynamics from multiple sources of monitoring information. The posterior median estimate of β_{Lat} was negative equaling -0.069 (Table H.1) and similar to the estimate of -0.0741 from Runge and Boomer (2005) indicating that, all else being equal, annual increases in the latitude of the observed breeding population results in a smaller observed breeding population estimated with the WBPMS. The posterior median estimate of the balance equation bias correction term (γ_R) was 0.565 indicating that annual recruitment needed to be adjusted down to minimize overprediction bias. Median estimates of the male fraction of the pintail population were variable ranging from (0.52 to 0.60).

Recruitment

Pintail recruitment modeled with juvenile to adult female age ratios was variable ranging from 0.53 to 1.64. The pintail recruitment model resulted in a posterior median estimate of the slope parameter for the density dependent term less than zero (-0.083) suggesting strong evidence for negative density dependence in pintail productivity (Table H.2). In addition, the posterior median estimate of the slope parameter for the breeding latitude covariate (β_2) was also negative (-0.124), indicative of lower expected pintail recruitment in overflight years and consistent with relationships found in earlier studies (Runge and Boomer 2005, Osnas et al. 2016; 2021).

Table H.2 – Summary of posterior statistics for the recruitment parameters estimated with the pintail IPM.

variable	mean	median	sd	q2.5	q97.5	rhat	ess_bulk	ess_tail
β_0	-0.081	-0.081	0.034	-0.148	-0.012	1.001	5,080	5,867
β_1	-0.083	-0.083	0.030	-0.144	-0.024	1.000	6,277	6,349
β_2	-0.124	-0.124	0.017	-0.157	-0.090	1.000	6,539	6,402
σ_R	0.168	0.166	0.030	0.113	0.230	1.001	2,377	3,680

Harvest and Survival

Pintail harvest rates of all cohorts were highest in the 1960s and then gradually decreased through the mid 1980s when more restrictive regulations were enacted (Raveling and Heitmeyer 1989, Rice et al. 2010) and as the number of active hunters has declined. Posterior estimates for the B_1 terms in the survival sub-models were variable, particularly for females, and suggest a partial compensatory response (Conroy and Kremetz 1990) to harvest mortality (Table H.3). These results are consistent with previous band recovery analyses that were unable to find fully additive relationships between harvest and natural mortality (Bartzen and Dufour 2017). The median adult female slope estimate (β_1) was 0.19 (0.01,0.61 95% CI), providing some evidence that adult female harvest mortality may be compensated by changes in natural mortality, whereas, the median estimate for adult males was 0.97 (0.84–1.00 95% CI), suggesting that harvest mortality may be additive to natural mortality for this cohort. However, caution is warranted in drawing strong conclusions about the causal relationships between changes in harvest rates and variation in annual survival for pintails. Recent work modeling relationships between harvest and natural mortality as a function of covariates (e.g., hunting effort) and density dependence offer alternative explanations for the patterns in observed survival and

Table H.3 – Summary of posterior statistics for the survival sub-model parameters estimated with the pintail IPM.

variable	mean	median	sd	q2.5	q97.5	rhat	ess_bulk	ess_tail
$SO_{j,f}$	0.675	0.677	0.019	0.633	0.709	1.000	9,989	6,003
$SO_{j,m}$	0.769	0.770	0.013	0.740	0.792	1.001	10,864	6,694
$SO_{a,f}$	0.657	0.656	0.005	0.649	0.669	1.000	11,482	6,228
$SO_{a,m}$	0.793	0.793	0.002	0.787	0.797	1.000	8,762	5,615
$\beta_{1,j,f}$	0.778	0.832	0.193	0.275	0.994	1.000	9,071	6,297
$\beta_{1,j,m}$	0.917	0.941	0.082	0.693	0.998	1.000	8,090	6,160
$\beta_{1,a,f}$	0.218	0.188	0.165	0.008	0.613	1.000	9,587	5,843
$\beta_{1,a,m}$	0.954	0.965	0.042	0.841	0.998	1.000	8,037	5,363

harvest estimates and suggest how the more simplified models may limit our ability to uncover the true underlying relationship between harvest mortality and annual survival (Riecke et al. 2022a;b).

The posterior median estimate of the total harvest bias scaling term (γ_H) was equal to 2.4, which indicates that our model-based estimates of harvest needed to be scaled up to be consistent with total harvest estimates from the HIP survey (see Table H.1). Based on this result, we should adjust observed pintail harvest estimates from the HIP survey down by a factor of 0.42, which is lower than the bias corrections estimated for mallards (0.73) and Canada goose (*Branta Canadensis*, 0.61 and 0.67) harvest totals suggested by Padding and Royle (2012). It is important to recognize that an alternative explanation for these discrepancies is that the breeding population (BPOP) is underestimated even after accounting for overflight bias. While there are probably many factors that could influence these biases in the pintail monitoring programs, our harvest management decision frameworks are predicated on annual observations of the BPOP from the WBPHS. As a result, we have chosen to use the BPOP observations as the baseline to serve as the reference point when reconciling the scaling issues associated with the pintail monitoring programs.

Equilibrium Analysis

An equilibrium analysis of the new Integrated Population Model reveals the underlying harvest potential for pintails (Figure H.2). At an average settling latitude of 55.7 degrees N, the equilibrium breeding population size in the absence of harvest (i.e., the carrying capacity) is 3.56 million on the corrected scale (equivalent to an observed breeding population of 2.70 million). The maximum sustained yield occurs at a harvest rate of 0.0932 (9.32 % of the fall flight is harvested), and the equilibrium population size at this harvest rate is 1.70 million on the corrected scale (1.29 on the observed scale). The expected observed continental harvest at this equilibrium point is 524,000 birds.

The average settling latitude prior to the 1980s was 53.5 degrees N. In these historical conditions, reproductive rates were considerably higher, resulting in a carrying capacity of 6.87 on the corrected scale (6.07 on the observed scale), with a harvest rate of 0.1896 and an equilibrium population size of 3.07 million at the maximum sustained yield. The expected observed continental harvest at the maximum sustained yield was 2,160,000 birds. Thus, the habitat and climate changes that occurred in the mid-1980s reduced the carrying capacity for pintails by 48% (from 6.07 to 3.56 million) and the maximum sustained yield by 76% (from 2.16 million to 524 thousand).

The new harvest models that were developed as part of the comprehensive revision of the pintail analysis are now a function of the fall flight; previously, the predicted total continental harvest was a function of regulations, but was not influenced by the population size or fall flight. The expected harvests under L1, L2, and L3 packages (with a fixed L3-bag for the Atlantic Flyway) intercept the current yield curve on the right shoulder, suggesting that sustainable harvest is possible with these packages.

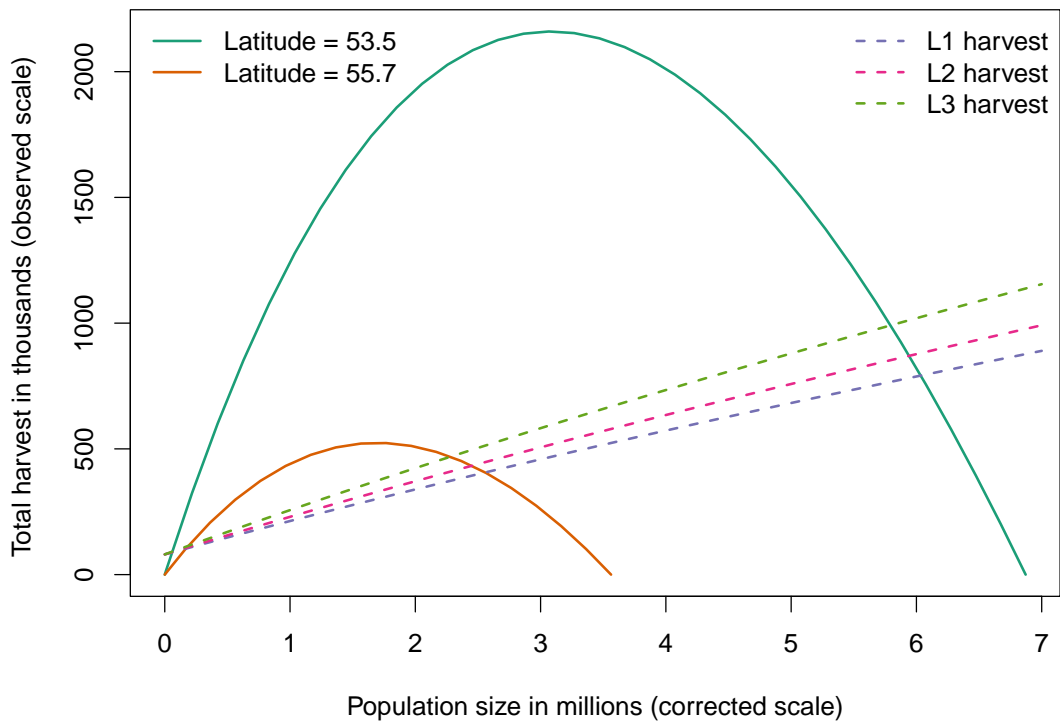

Figure H.2 – Yield curve for the continental, northern pintail population, under two scenarios of mean settling latitude. Prior to 1980, pintails settled farther south, at an average latitude of 53.5°N; after approximately 1980, the average settling latitude is 55.7°N. This change in distribution has decreased the reproductive rate and greatly reduced the yield curve, including the carrying capacity and the maximum sustained yield. The dashed lines show the expected total North American harvest under three U.S. harvest regulations, assuming the higher settling latitude.

Table H.4 – Expected recoveries of pre-season banded birds involving both solicited and unsolicited band reporting. For clarity, we present expected number of recoveries for a single cohort, recognizing that a full time (T) by age interactive model requires additional parameters.

Band releases in year i	Solicited recoveries in year j					Unsolicited recoveries in year j					Number not recovered
	1	2	3	...	T	1	2	3	...	T	
R_1	$R_1 \gamma_1 h_1$	$R_1 S_1 \gamma_2 h_2$	$R_1 S_1 S_2 \gamma_3 h_3$...	$R_1 S_1 S_2 \dots S_{T-1} \gamma_T h_T$	$R_1 (1 - \gamma_1) h_1 \lambda_1$	$R_1 S_1 (1 - \gamma_2) h_2 \lambda_2$	$R_1 S_1 S_2 (1 - \gamma_3) h_3 \lambda_3$...	$R_1 S_1 S_2 \dots S_{T-1} (1 - \gamma_T) h_T \lambda_T$	$R_1 - \sum_{j=1}^T E(m_{1,j})$
R_2		$R_2 \gamma_2 h_2$	$R_2 S_2 \gamma_3 h_3$...	$R_2 S_2 \dots S_{T-1} \gamma_T h_T$		$R_2 (1 - \gamma_2) h_2 \lambda_2$	$R_1 S_2 (1 - \gamma_3) h_3 \lambda_3$...	$R_2 S_2 \dots S_{T-1} (1 - \gamma_T) h_T \lambda_T$	$R_2 - \sum_{j=2}^T E(m_{2,j})$
R_3			$R_3 \gamma_3 h_3$...	$R_3 S_3 \dots S_{T-1} \gamma_T h_T$			$R_3 (1 - \gamma_3) h_3 \lambda_3$...	$R_3 S_3 \dots S_{T-1} (1 - \gamma_T) h_T \lambda_T$	$R_3 - \sum_{j=3}^T E(m_{3,j})$
...			
R_T				...	$R_T \gamma_T h_T$...	$R_T (1 - \gamma_T) h_T \lambda_T$	$R_T - \sum_{j=T}^T E(m_{T,j})$

R_i is the number of bands released pre-season in year i .

γ_j is the band solicitation rate in year j .

S_j is the survival rate in year j .

h_j is the harvest rate in year j .

λ_j is the band reporting rate in year t . For solicited bands, we assume band reporting rates equal to 1.0.

$E(m_{i,j})$ is the expected number of recoveries in year j from birds released in year i .

Table H.5 – Prior distributions of population parameters specified in a Bayesian estimation framework for the pintail IPM.

Parameter	Distribution	Source
β_0	Normal(0,100)	
β_1	Normal(0,100)	
β_2	Normal(0,100)	
σ_R	Exponential(1)	
$f_{juv,t}$	Beta(1,1)	
$f_{adult,t}$	Beta(1,1)	
$\lambda_{t=1961-1981}$	Beta(13.6,38.8)	(Osnas et al. 2021)
$\lambda_{t=1982-1989}$	Beta(19.0,40.4)	(Osnas et al. 2021)
$\lambda_{t=1990-1992}$	Beta(50.4,82.2)	(Osnas et al. 2021)
$\lambda_{t=1993}$	Beta(62.6, 83.6)	(Osnas et al. 2021)
$\lambda_{t=1994}$	Beta(75.5, 82.8)	(Osnas et al. 2021)
$\lambda_{t=1995}$	Beta(88.5, 80.0)	(Osnas et al. 2021)
$\lambda_{t=1996}$	Beta(101.1, 75.1)	(Osnas et al. 2021)
$\lambda_{t=1997}$	Beta(112.7, 68.4)	(Osnas et al. 2021)
$\lambda_{t=1998}$	Beta(122.3, 60.1)	(Osnas et al. 2021)
$\lambda_{t=1999-2002}$	Beta(128.7, 50.3)	(Osnas et al. 2021)
$\lambda_{t=2003-2006}$	Beta(98.4,35.5)	(Osnas et al. 2021)
$\lambda_{t=2007}$	Beta(196.3, 66.9)	(Boomer et al. 2023)
$\lambda_{t=2008}$	Beta(180.7, 57.4)	(Boomer et al. 2023)
$\lambda_{t=2009}$	Beta(180.0, 48.5)	(Boomer et al. 2023)
$\lambda_{t=2010}$	Beta(190.3, 41.1)	(Boomer et al. 2023)
$\lambda_{t=2011}$	Beta(179.2, 34.9)	(Boomer et al. 2023)
$\lambda_{t=2012}$	Beta(162.1, 32.3)	(Boomer et al. 2023)
$\lambda_{t=2013}$	Beta(135.1, 27.2)	(Boomer et al. 2023)
$\lambda_{t=2014}$	Beta(123.1, 23.4)	(Boomer et al. 2023)
$\lambda_{t=2015}$	Beta(134.6, 22.6)	(Boomer et al. 2023)
$\lambda_{t=2016}$	Beta(163.8, 23.7)	(Boomer et al. 2023)
$\lambda_{t=2017}$	Beta(174.7, 23.4)	(Boomer et al. 2023)
$\lambda_{t=2018}$	Beta(175.9, 22.0)	(Boomer et al. 2023)
$\lambda_{t=2019}$	Beta(191.8, 22.2)	(Boomer et al. 2023)
$\mu_{a,s}^{sol}$	Normal(0, 1.78)	
$\sigma_{a,s}^{sol}$	Normal(0, 1.0)	Constrained to be positive
$\mu_{a,s}^h$	Normal(0, 1.75)	
$\sigma_{a,s}^h$	Exponential(1.0)	
$S_{0,a,s}$	Beta(1,1)	
$\beta_{1,a,s}$	Beta(1,1)	
SS_m	Beta(109,3)	(Brasher et al. 2006)
SS_f	Beta(59,14)	(Richkus et al. 2005)
N_{Init}	Lognormal(1.25,0.5)	
m_{Init}	Beta(25,25)	
γ_R	Normal(0,1)	Constrained to be positive
γ_H	Uniform(0,7.4)	
$\sigma_{process}$	Normal(0,1)	Constrained to be positive
β_{Lat}	Normal(0,10)	

Appendix I Scaup Model

We use a state-space formulation of scaup population and harvest dynamics within a Bayesian estimation framework (Meyer and Millar 1999, Millar and Meyer 2000). This analytical framework allows us to represent uncertainty associated with the monitoring programs (observation error) and the ability of our model formulation to predict actual changes in the system (process error).

Process Model

Given a logistic growth population model that includes harvest (Schaefer 1954), scaup population and harvest dynamics are calculated as a function of the intrinsic rate of increase (r), carrying capacity (K), and harvest (H_t). Following Meyer and Millar (1999), we scaled population sizes by K (i.e., $P_t = N_t/K$) and assumed that process errors (ϵ_t) are lognormally distributed with a mean of 0 and variance $\sigma_{process}^2$. The state dynamics can be expressed as

$$P_{1974} = P_0 e^{\epsilon_{1974}}$$

$$P_t = (P_{t-1} + rP_{t-1}(1 - P_{t-1}) - H_{t-1}/K) e^{\epsilon_t}, \quad t = 1975, \dots, 2024,$$

where P_0 is the initial ratio of population size to carrying capacity. To predict total scaup harvest levels, we modeled scaup harvest rates (h_t) as a function of the pooled direct recovery rate (f_t) observed each year with

$$h_t = f_t / \lambda_t.$$

We specified reporting rate (λ_t) distributions based on data for mallards (*Anas platyrhynchos*) from large scale historical and existing reward banding studies (Henny and Burnham 1976, Nichols et al. 1995b, P. Garrettson unpublished data). We accounted for increases in reporting rate believed to be associated with changes in band type (e.g., from AVISE and new address bands to 1-800 toll free and web address) by specifying year specific reporting rates (Boomer et al. unpublished estimates).

We then predicted total scaup harvest (H_t) with

$$H_t = h_t [P_t + rP_t(1 - P_t)] K, \quad t = 1974, \dots, 2023.$$

Observation Model

We compared our predictions of population and harvest numbers from our process model to the observations collected by the Waterfowl and Breeding Habitat Survey (WBPHS) and the Harvest Survey programs with the following relationships, assuming that the population and harvest observation errors were additive and normally distributed. May breeding population estimates were related to model predictions by

$$N_t^{Observed} - P_t K = \epsilon_t^{BPOP},$$

where

$$\epsilon_t^{BPOP} \sim N(0, \sigma_{t,BPOP}^2), \quad t = 1974, \dots, 2019, \text{ and } 2022 - 2024,$$

where $\sigma_{t,BPOP}^2$ is specified each year with the BPOP variance estimates from the WBPHS.

We adjusted our harvest predictions to the observed harvest data estimates with a scaling parameter (q) according to

$$H_t^{Observed} - (h_t [P_t + rP_t (1 - P_t)] K) / q = \varepsilon_t^H, \quad t = 1974, \dots, 2023,$$

where,

$$\varepsilon_t^H \sim N(0, \sigma_{t,Harvest}^2).$$

We assumed that appropriate measures of the harvest observation error $\sigma_{t,Harvest}^2$ could be approximated by assuming a coefficient of variation for each annual harvest estimate equal to 0.15 (Paul Padding pers. comm.). The final component of the likelihood included the year specific direct recovery rates that were represented by the rate parameter (f_t) of a Binomial distribution indexed by the total number of birds banded preseason and estimated with,

$$f_t = m_t / M_t,$$

$$m_t \sim \text{Binomial}(M_t, f_t)$$

where m_t is the total number of scaup banded preseason in year t and recovered during the hunting season in year t and M_t is the total number of scaup banded preseason in year t .

Bayesian Analysis

Following Meyer and Millar (1999), we developed a fully conditional joint probability model, by first proposing prior distributions for all model parameters and unobserved system states and secondly by developing a fully conditional likelihood for each sampling distribution.

Prior Distributions

For this analysis, a joint prior distribution is required because the unknown system states P are assumed to be conditionally independent (Meyer and Millar 1999). This leads to the following joint prior distribution for the model parameters and unobserved system states

$$P(r, K, q, f_t, \lambda_t, \sigma_{Process}^2, P_0, P_1, \dots, T) =$$

$$p(r)p(K)p(q)p(f_t)p(\lambda_t)p(\sigma_{Process}^2)p(P_0)p(P_1|P_0, \sigma_{Process}^2)$$

$$\times \prod_{t=2}^n p(P_t|P_{t-1}, r, K, f_{t-1}, \lambda_{t-1}, \sigma_{Process}^2)$$

In general, we chose non-informative priors to represent the uncertainty we have in specifying the value of the parameters used in our assessment. However, we were required to use existing information to specify informative priors for the initial ratio of population size to carrying capacity (P_0) as well as the reporting rate values (λ_t) specified above that were used to adjust the direct recovery rate estimates to harvest rates.

We specified that the value of P_0 , ranged from the population size at maximum sustained yield ($P_0 = N_{MSY}/K = (K/2)/K = 0.5$) to the carrying capacity ($P_0 = N/K = 1$), using a uniform distribution on the log scale to represent this range of values. We assumed that the exploitation experienced at this population state was somewhere on the right-hand shoulder of a sustained yield curve (i.e., between MSY and K). Given that we have very little evidence to suggest that historical scaup harvest levels were limiting scaup population growth, this seems like a reasonable prior distribution.

We used non-informative prior distributions to represent the variance and scaling terms, while the priors for the population parameters r and K were chosen to be vague but within biological bounds. These distributions were specified according to

$$\begin{aligned}
P_0 &\sim \text{Uniform}(\ln(0.5), 0), \\
K &\sim \text{Lognormal}(2.17, 0.667), \\
r &\sim \text{Uniform}(0.00001, 2), \\
f_t &\sim \text{Beta}(0.5, 0.5), \\
q &\sim \text{Uniform}(0.0, 2), \\
\sigma_{Process}^2 &\sim \text{Inverse Gamma}(0.001, 0.001).
\end{aligned}$$

Likelihood

We related the observed population, total harvest estimates, and observed direct recoveries to the model parameters and unobserved system states with the following likelihood function:

$$\begin{aligned}
&P(N_{1,\dots,T}, H_{1,\dots,T}, m_{1,\dots,T} | M_{1,\dots,T} | r, K, f_t, \lambda_t, q, \sigma_{Process}^2, \sigma_{Harvest}^2, P_{1,\dots,T}) = \\
&\quad \times \prod_{t=1}^T p(N_t | P_t, K, \sigma_{BPOP}^2) \times \prod_{t=1}^T p(H_t | P_t, r, K, q, f_t, \lambda_t, \sigma_{Harvest}^2) \\
&\quad \times \prod_{t=1}^T p(m_t | M_t, f_t)
\end{aligned}$$

Posterior Evaluation

Using Bayes theorem we then specified a posterior distribution for the fully conditional joint probability distribution of the parameters given the observed information according to

$$\begin{aligned}
&P(r, K, q, f_t, \lambda_t, \sigma_{Process}^2, P_0, P_{1,\dots,T} | N_{1,\dots,T}, H_{1,\dots,T}, m_{1,\dots,T}, M_{1,\dots,T}) \propto \\
&\quad p(r)p(K)p(q)p(f_t)p(\lambda_t)p(\sigma_{Process}^2)p(P_0)p(P_1 | P_0, \sigma_{Process}^2) \\
&\quad \times \prod_{t=2}^n p(P_t | P_{t-1}, r, K, f_{t-1}, \lambda_{t-1}, \sigma_{Process}^2) \times \prod_{t=1}^T p(N_t | P_t, K, \sigma_{BPOP}^2) \\
&\quad \times \prod_{t=1}^T p(H_t | P_t, r, K, q, f_t, \lambda_t, \sigma_{Harvest}^2) \times \prod_{t=1}^T p(m_t | M_t, f_t)
\end{aligned}$$

We used MCMC methods to evaluate the posterior distribution using WinBUGS (Spiegelhalter et al. 2003). We randomly generated initial values and simulated 5 independent chains each with 1,000,000 iterations. We discarded the first half of the simulation and thinned each chain by 250, yielding a sample of 10,000 points. We calculated Gelman-Rubin statistics (Brooks and Gelman 1998) to monitor for lack of convergence. The state-space formulation and Bayesian analysis framework provided reasonable fits to the observed breeding population and total harvest estimates with realistic measures of variation. The 2024 posterior estimates of model parameters based on data from 1974 to 2024 are provided in Table I.1.

Table I.1 – Model parameter estimates resulting from a Bayesian analysis of scaup breeding population observations from 1974–2024, along with harvest and banding information from 1974–2023.

Parameter	Mean	SD	2.5% CI	Median	97.5% CI
r	0.1261	0.0379	0.0643	0.1210	0.2152
K	9.1341	1.7258	6.4039	8.9370	12.7500
σ^2	0.0079	0.0029	0.0036	0.0074	0.0149
q	0.7625	0.0376	0.6923	0.7613	0.8386

We further summarized the simulation results for r , K , and the scaling parameter q to admit parametric uncertainty with a formal correlation structure within the optimization procedure used to calculate the harvest strategy. We first defined a joint distribution for 3 discrete outcomes for each of the 3 population parameters. We used the 30 and 70 percent quantiles for each parameter as the cut points to define three bins for which to discretize 3 values of each posterior distribution. We then determined the frequency of occurrence of each of the 27 possible combinations of each parameter value falling within the 3 bins from the MCMC simulation results. These frequencies were then assigned parameter values based on the midpoint of the bin ranges (15, 50, 85 percent quantiles) to specify the joint distribution of the population parameter values used in the optimization.

Division of Migratory Bird Management
11510 American Holly Dr.
Laurel, MD 20708-4016

U.S. Fish & Wildlife Service
<https://www.fws.gov>

For state transfer relay service
TTY/Voice: 711

